

Models No. ▶ JR3020

Description ▶ Recipro Saw

CONCEPTION AND MAIN APPLICATIONS

Model JR3020 employs the most powerful motor in its class (1,020 W) and orbital cutting action mechanism for fast, smooth cutting in various materials. You can select a cutting action suitable for your work using the one-touch lever : straight line, small orbit, medium orbit or large orbit cutting actions.

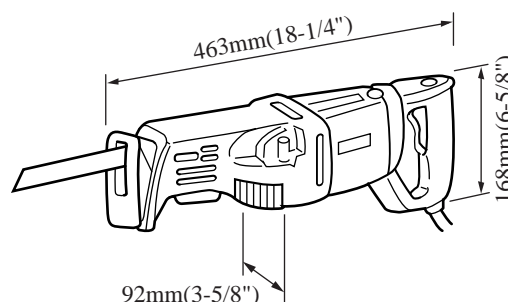

► Specifications

| Voltage (V) | Current (A) | Cycle (Hz) | Continuous Rating (W) | | Max. Output(W) |
|-------------|-------------|------------|-----------------------|--------|----------------|
| | | | Input | Output | |
| 100 | 10.7 | 50/60 | 1,020 | 580 | 1,200 |
| 115 | 9.3 | 50/60 | 1,020 | 580 | 1,200 |
| 200 | 5.4 | 50/60 | 1,020 | 580 | 1,200 |
| 220 | 4.9 | 50/60 | 1,020 | 580 | 1,200 |
| 230 | 4.7 | 50/60 | 1,020 | 580 | 1,200 |
| 240 | 4.5 | 50/60 | 1,020 | 580 | 1,200 |

| | | |
|-----------------------------|------|------------------|
| Max.Cutting Capacity | Pipe | 90 mm (3-1/2") |
| | Wood | 90 mm (3-1/2") |
| Length of Stroke | | 30 mm (1-3/16") |
| Strokes per Minute | | 0 - 2,500 |
| Net Weight | | 3.8 kg (8.4 lbs) |

► Standard equipment

Recipro Saw Blade No.21, No. 22, No. 23, Hex Wrench, Plastic Carrying Case

► Optional accessories

Recipro Saw Blade No. 21, No. 22, No. 24 (for steel), Recipro Saw Blade No.23, 23B (for wood)