

Rotary Hammer

HR4010C

REPAIR MANUAL



► Repair

CAUTION: Disconnect the machine from the power source for safety before repair/maintenance!

[1] NECESSARY REPAIRING TOOLS

Code No.	Description	Use for
1R003	Retaining Ring S Pliers ST-2N	Removing/ installing Ring springs
1R022	Bearing Plate	Removing Helical gear 38
1R045	Gear extractor, large	Removing Armature
1R167	T-Type Hex Wrench 3-70	Removing Barrel cover complete
1R212	Tip for Retaining Ring Pliers	Removing/ installing Ring springs (for modular use with No.1R003)
1R213	Cylinder Extractor	Removing Cylinder
1R214	Taper Sleeve	Installing Fluoride ring
1R269	Bearing Extractor	Replacing Ball bearings
1R230	1/4" Hex Shank Bit for M6	Removing/ installing Barrel complete
1R346	Center Attachment for 1R045	Removing Armature (for modular use with 1R045)
1R350	Ring 60	Removing Cylinder

[2] LUBRICATION

Apply the following grease to the portions designated with the triangle to protect parts and product from unusual abrasion.

Item No.	Description	Grease type	Portion to lubricate
22	Tool holder	R.No.00	About 5g on the inside surface that contacts Impact bolt
		N.No.2	Two elliptic holes that contact Tool retainers
			Outside surface that contacts Spacer and Chuck ring
24	O ring 20 on impact bolt	R.No.00	Whole portion
25	Fluoride ring 25 on impact bolt		
26	X ring 18 on impact bolt		
32	O ring 22 on striker		
37	O ring 21 on piston		
38	O ring 22 on piston		
46	Cylinder 28.5		About 5g on the inside surface that contacts Piston and Impact bolt

Fig. 1A

▼ :Makita grease R.No.00

▽ :Makita grease N.No.2

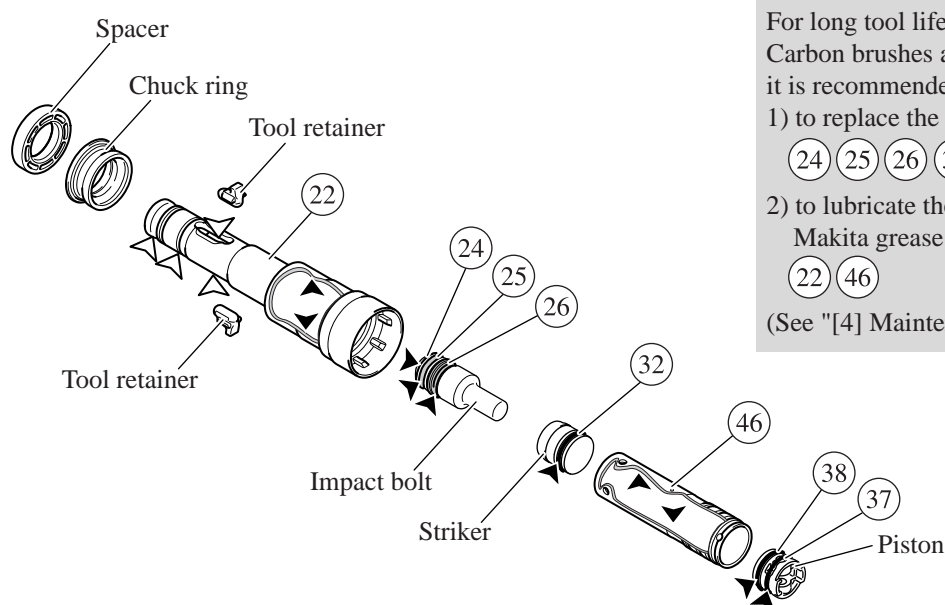

Note:

For long tool life, at the same time when Carbon brushes are replaced, it is recommended;

1) to replace the following parts:

(24) (25) (26) (32) (38)

2) to lubricate the following parts with Makita grease R.No.00:

(22) (46)

(See "[4] Maintenance Program".)

► **Repair**

[2] LUBRICATION

Apply Makita grease R. No.00 to the portions designated with black triangle to protect parts and product from unusual abrasion.

Item No.	Description	Portion to lubricate
80	Crank housing complete	About 20g into the Crank room
83	O ring 18	Whole portion
86	Crank shaft	Crank pin portion
89	Helical gear 38	Teeth portion
90	Flat washer 10	Surface that contacts (89) Helical gear 38
92	Gear housing complete	About 22g into the Gear room
99	Driving flange	Surface that contacts Torque limiter assembly
---	Torque limiter assembly	Teeth portion of Helical gear 61
		Teeth portion of Straight bevel gear 7
Active dynamic vibration absorber of HR4010C and HR4011C		
54	Counter weight (2 pcs)	Surface that contacts Pipe 16

Fig. 1B

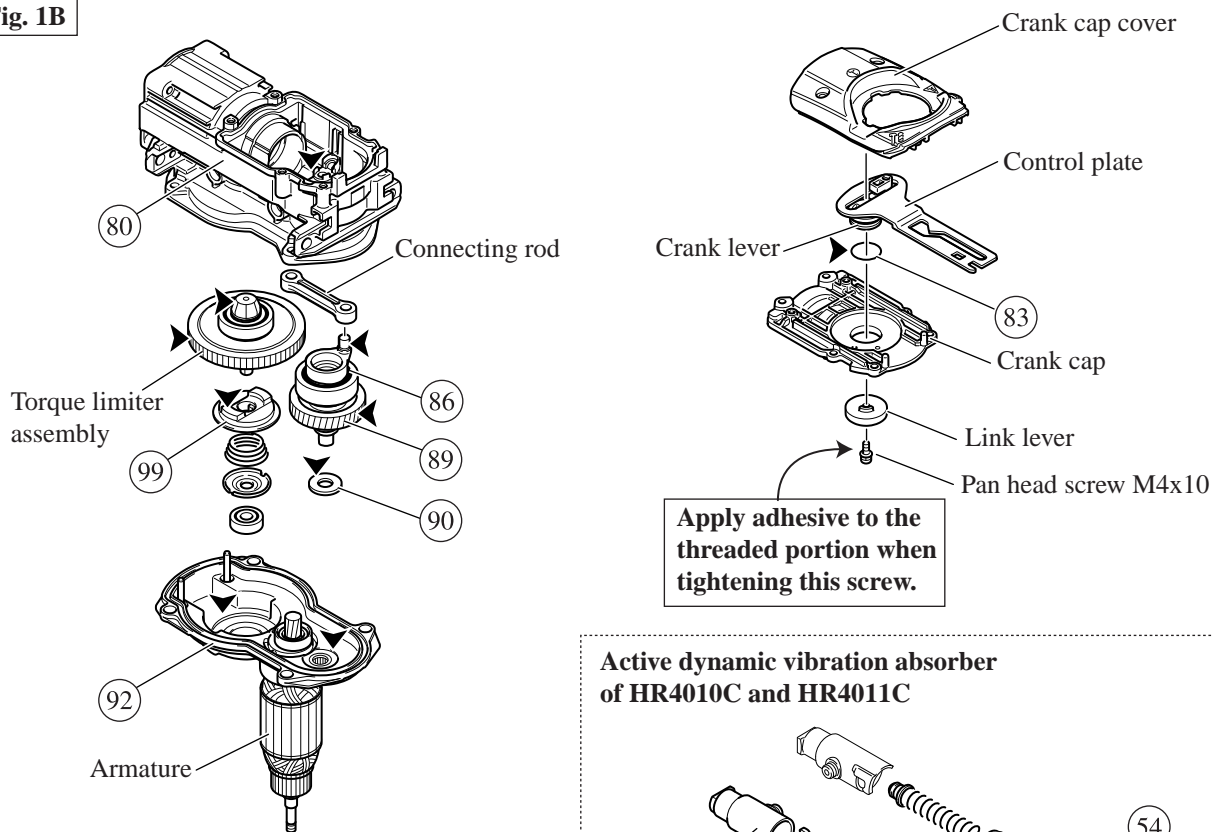

Note:
 For long tool life, at the same time when Carbon brushes are replaced, it is recommended to lubricate (80) Crank housing complete with Makita grease R.No.00. (See "[4] Maintenance Program".)

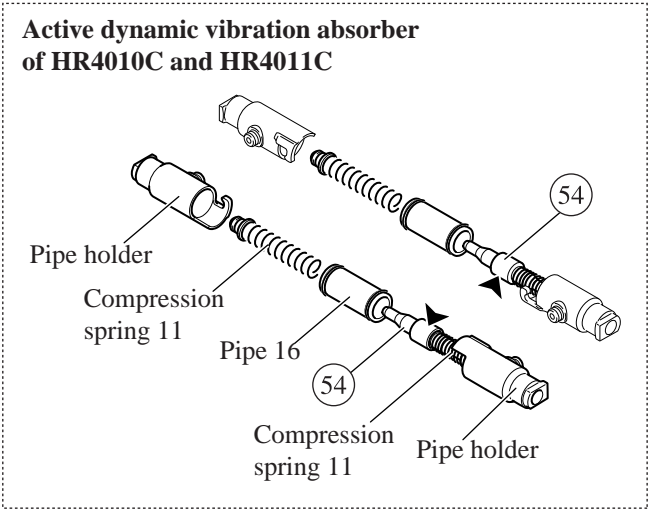

► Repair

[3] DISASSEMBLY/ASSEMBLY

[3] -1. Chuck Section

DISASSEMBLING

- 1) Remove Tool holder cap with a slotted screwdriver and by hand. Using Retaining ring S pliers ST-2N (No.1R003), put Ring spring 25 out of the ring installation groove on Tool holder. Then using No.1R003 and Tip for retaining ring pliers (No.1R212), remove Ring spring 25 from Tool holder. Now Flat washer 28, Chuck cover and Spacer can be removed. **(Fig. 2)**
- 2) Remove the other Ring spring 25 using No.1R003 and No.1R212. Chuck ring and Release cover can now be removed. Now you will see a pair of Tool retainers assembled on Tool retainer. **(Fig. 3)**
- 4) Remove the two Tool retainers while pushing down Spring guide towards the Barrel cover side. **(Fig. 4)**
- 5) Remove Spring guide and Compression spring 48, and unscrew Hex socket head bolt M4x16 using No.1R167 or hex wrench 3. Barrel cover complete can be now removed. **(Fig. 5)**

Fig. 2

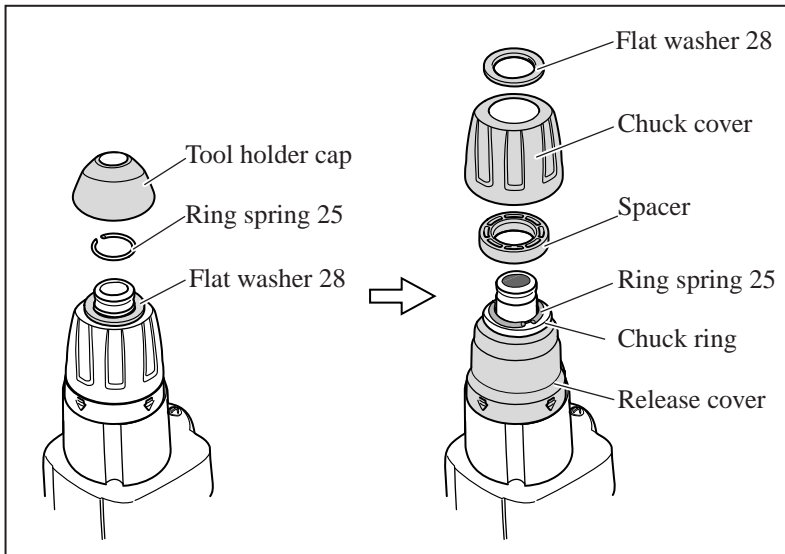

Fig. 3

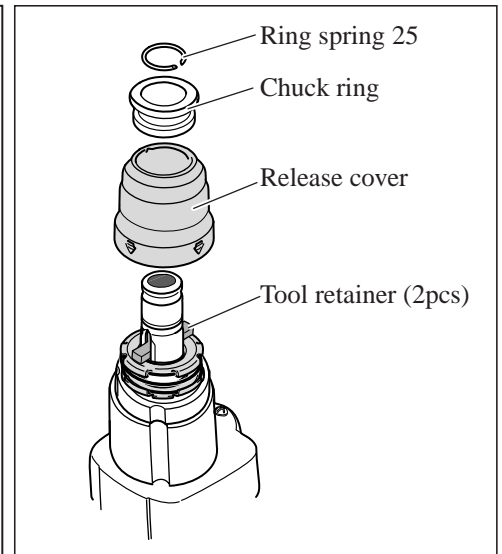

Fig. 4

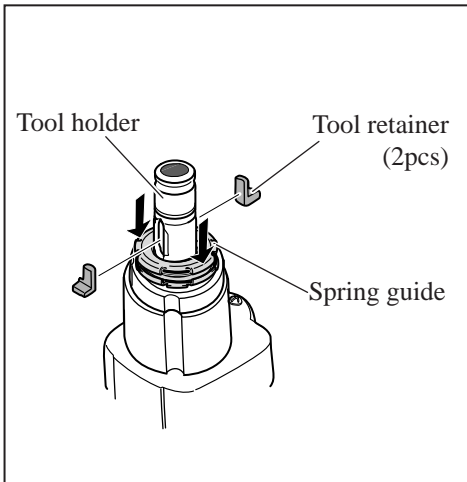
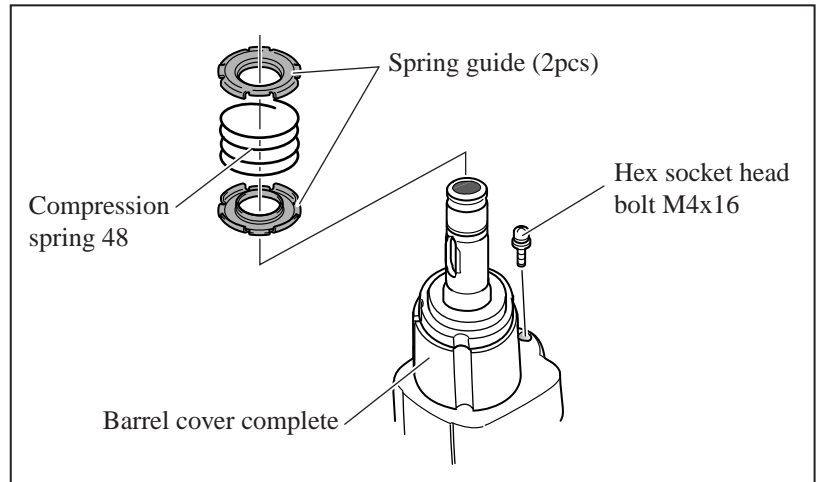

Fig. 5



ASSEMBLING

Do the reverse of the the disassembling steps.

► Repair

[3] DISASSEMBLY/ASSEMBLY

[3] -2. Blowing Mechanism (Impact bolt, Striker, etc.)

DISASSEMBLING

- 1) In order to replace the inner parts of the blowing mechanism, first remove Crank housing cover after removing the Chuck section, (Fig. 6)

Fig. 6

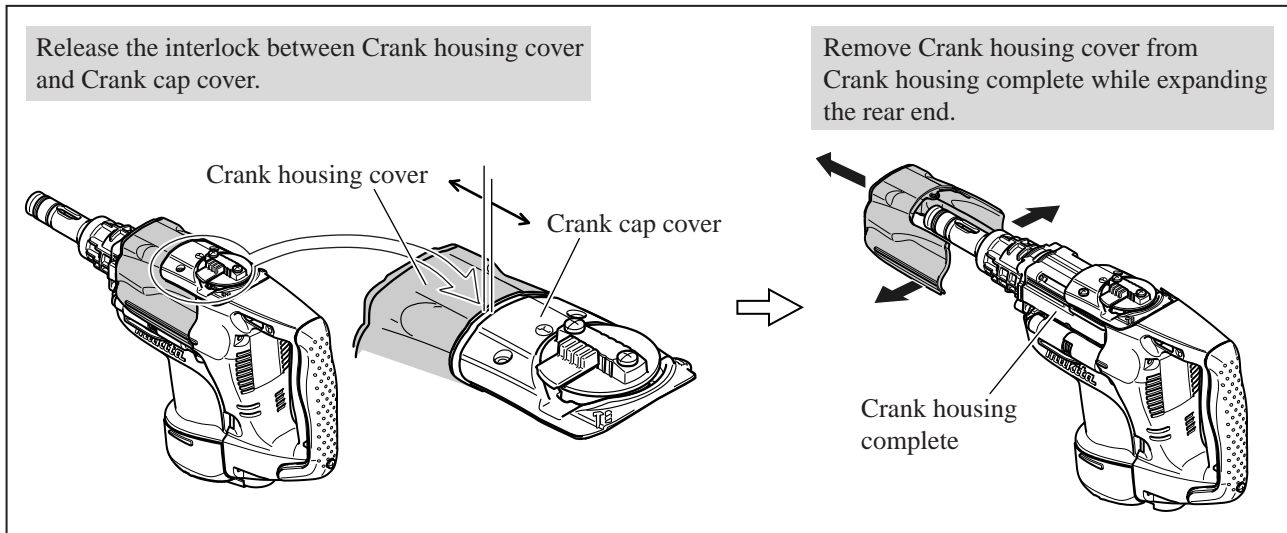

- 2) Then remove the assembly of Barrel complete and Tool holder (Fig. 7).

- 3) Remove Impact bolt from Tool holder by tapping the edge of Tool holder with plastic hammer. (Fig. 8)

Important:

If contaminated with dust, clean up the inside of Tool holder.

- 4) O ring 20 is installed under Fluoride ring 25. If Fluoride ring 25 is worn out, the orange color of O ring 20 will be visible. (Fig. 9) In this case, replace Fluoride ring 25 together with O ring 20 and X ring 18. Do not replace the Fluoride ring alone.

Fig. 7

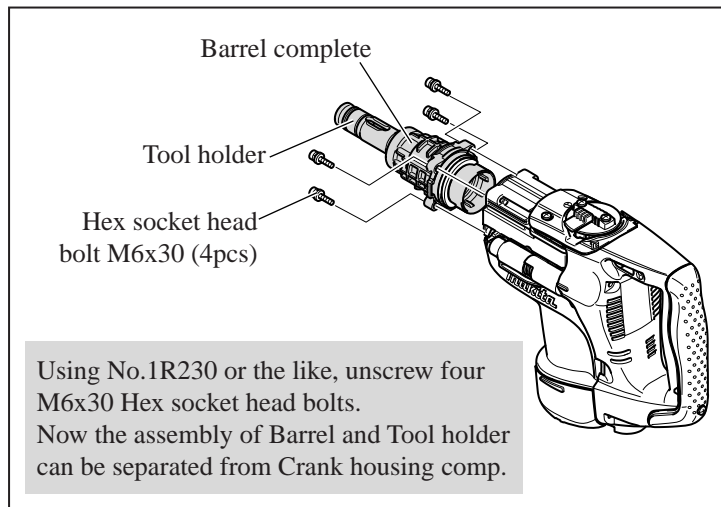

Fig. 8

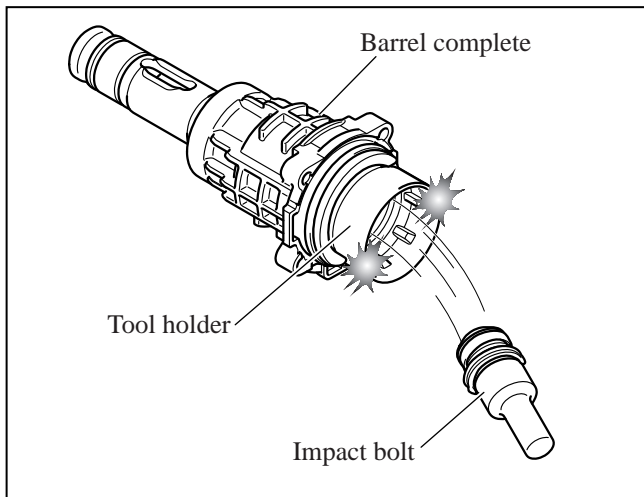
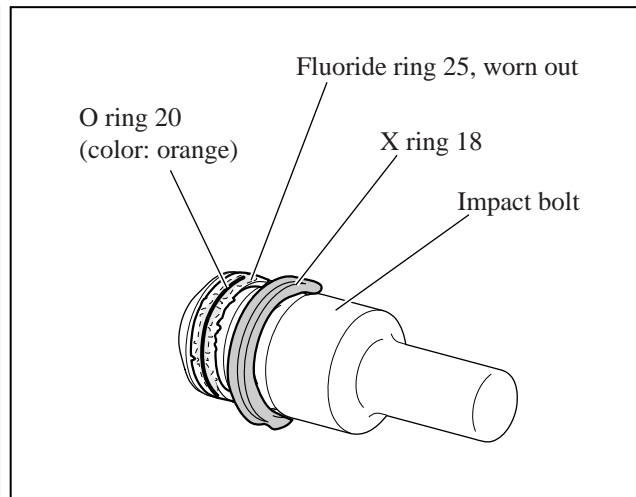

Fig. 9



► **Repair**

[3] DISASSEMBLY/ASSEMBLY

5) Separate Tool holder from Barrel complete.
Then remove Urethane ring 45 and Flat washer 45 from Tool holder. (Fig. 10)

Fig. 10

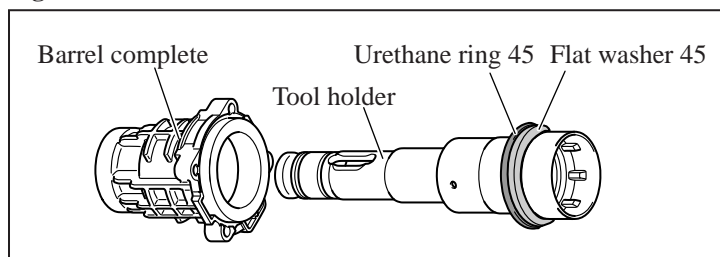

6) From Crank housing complete, remove Ring 17, Rubber ring 17, Slide sleeve, Ring 33, Compression spring 37 and Striker.
Remove O ring 22 from Striker. (Fig. 11)

Fig. 11

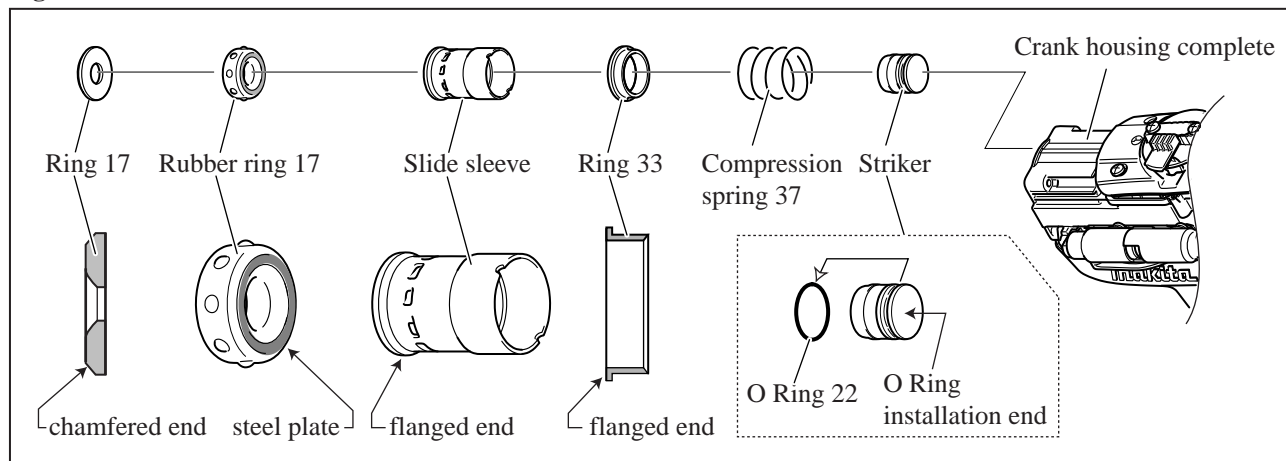

ASSEMBLING

Do the reverse of the disassembling steps. Be sure to remember the following notes.

Note 1) When assembling Fluoride ring to Impact bolt;

After installing Fluoride ring 25 on the groove of Impact bolt, the Ring is stretched and its edges are protruding from the groove. In order to correct the deformation, insert the Ring into the repairing tool, Taper Sleeve (Tool No.1R214), and leave it in the tool **about one minute**. (Fig. 12)

Fig. 12

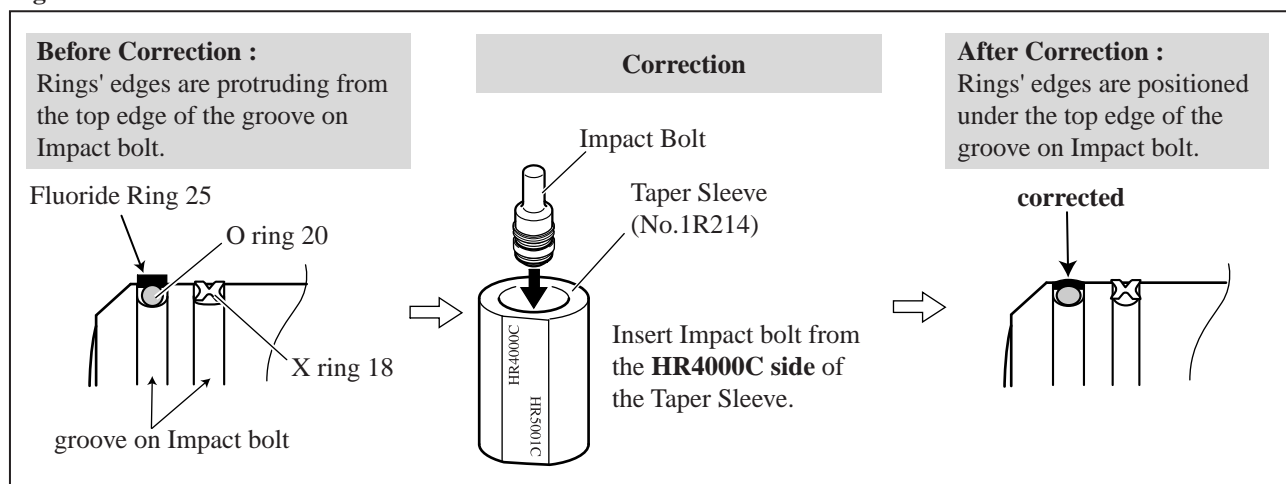

Note 2) The installations are not exchangeable between Urethane washer 45 and Flat washer 45 when they are assembled to Tool holder. (See Fig. 10.)

Note 3) Be sure that the following parts are not reversible when assembled; Fig. 13

- Impact bolt (See Fig. 13.)
- Ring 17, Rubber ring 17, Slide sleeve, Ring 33, Striker (See Fig. 11.)

Note:

When inserting Impact bolt into Tool holder, be careful not to push the rings out of the groove on Impact bolt.

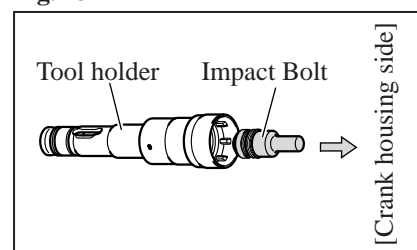

► **Repair**

[3] DISASSEMBLY/ASSEMBLY

[3] -3. Crank Section

DISASSEMBLING

1) After removing the parts of the blowing mechanism (Refer to [3]-2.), remove Handle, Change lever and Crank cap cover by unscrewing Tapping screws as illustrated in **Fig. 14**.

Fig. 14

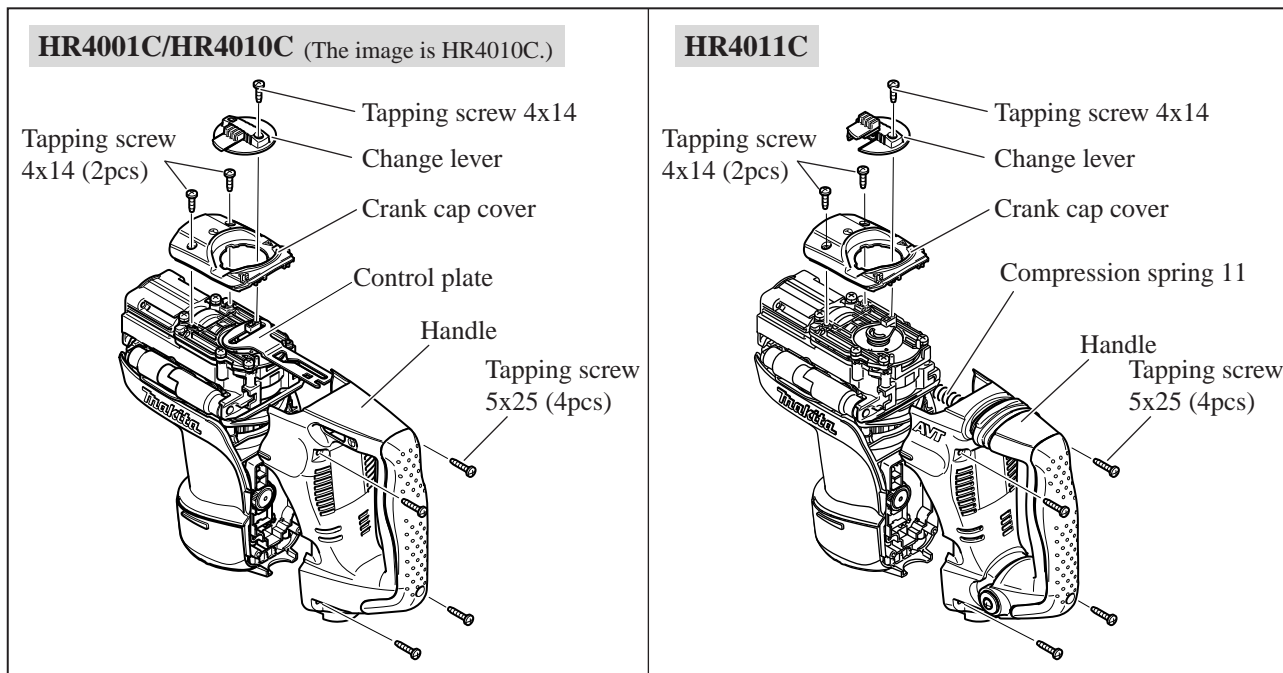

2) See **Fig. 15**.

By unscrewing six M4x18 pan head screws;

HR4001C/HR4010C:

Remove the assembly of Crank cap and Control plate.

HR4011C: Remove Crank cap.

Seal ring between Crank cap and Crank housing complete can be removed in this step.

Fig.15

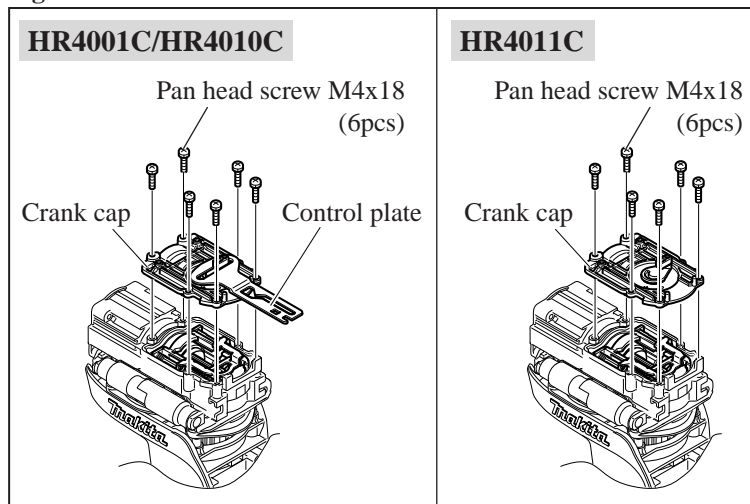

3) Remove Link plate together with link plate guide while pushing toward the Tool holder side. (**Fig. 16**)

Fig. 16

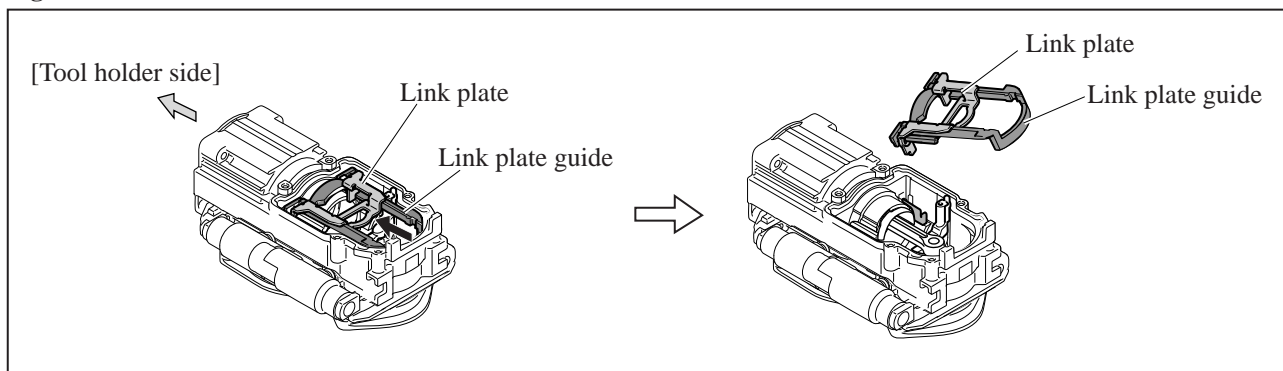

► **Repair**

[3] DISASSEMBLY/ASSEMBLY

4) Remove Lock sleeve from Crank housing complete as illustrated in **Fig. 17**. Then remove Spiral bevel gear 25.

Fig. 17

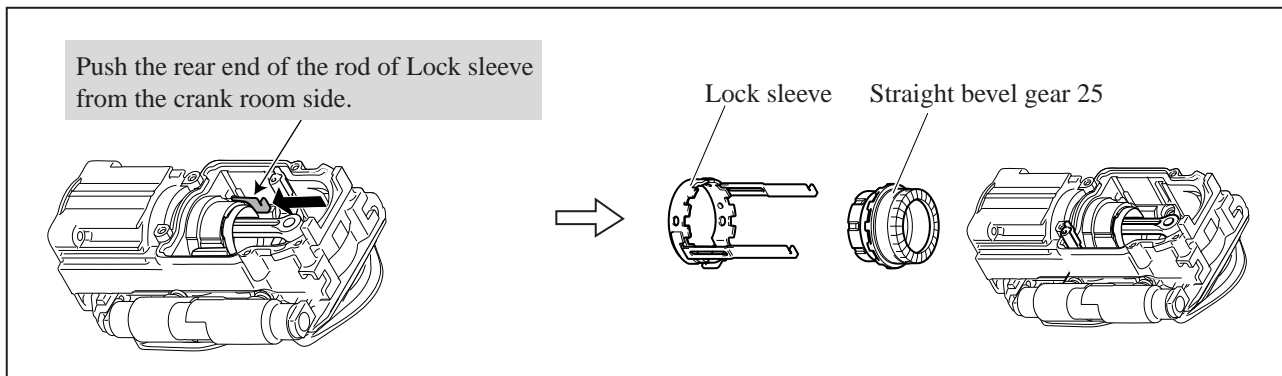

5) In order to separate Cylinder from Crank housing complete, first remove Ring spring 31 from the end of Cylinder 28.5 with a small screwdriver. Then remove Ring 33 from Cylinder 28.5. (**Fig. 18**)

HR4010C/ HR4011C: Two Seal plates, Air pipe and two Air pipe seals can be replaced in this step. (**Fig. 19**)

Fig. 18

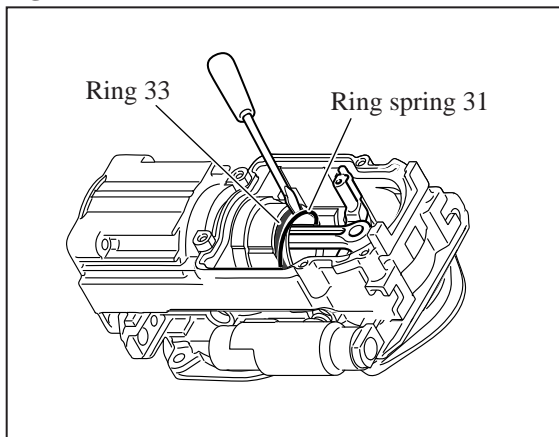
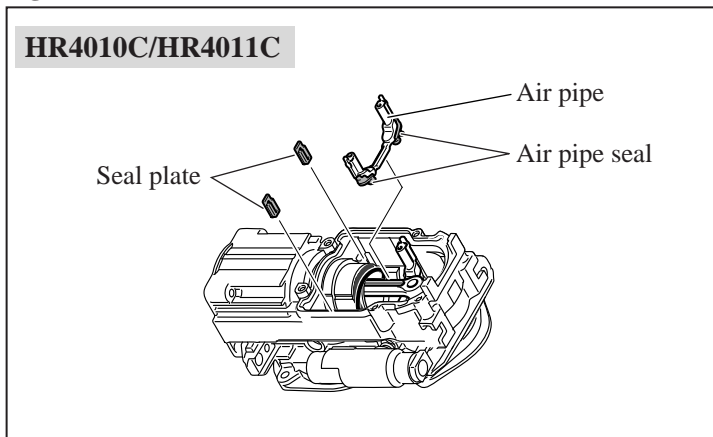

Fig. 19



6) Set Cylinder Extractor (No.1R213) and two diameter 60 Rings (No.1R350) on Cylinder 28.5 and Crank housing complete as illustrated in **Fig. 20**. And pull off the Cylinder by turning the handle of the Extractor clockwise. Use two Phillips screwdrivers as illustrated in **Fig. 21** if No.1R213 and No.1R350 are not available.

Fig. 20

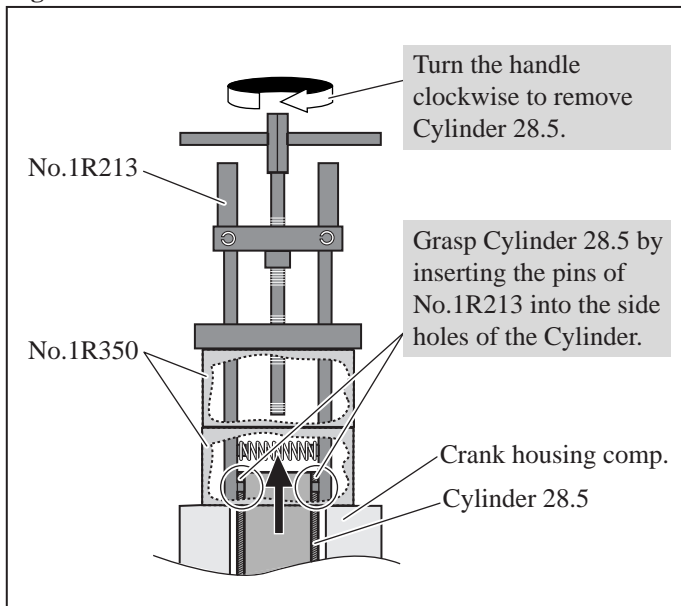
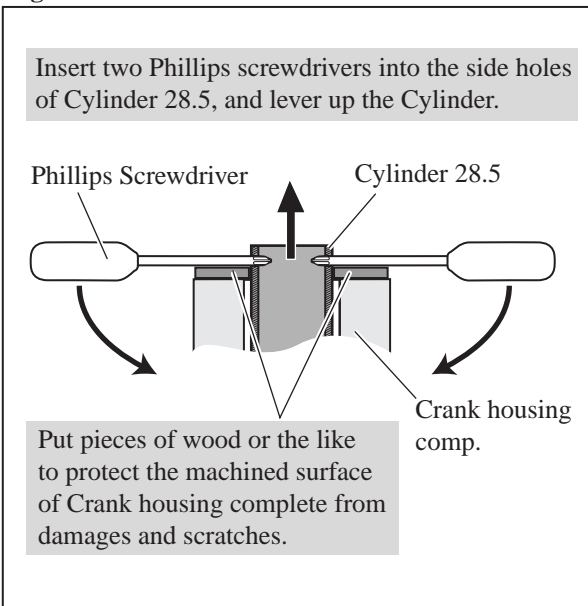

Fig. 21



► Repair

[3] DISASSEMBLY/ASSEMBLY

- 7) Place Piston at the rear dead point by turning Crank shaft. Then remove Piston and Rod from Crank shaft.
O ring 21 and O ring 22 can now be replaced. (Fig. 22)

Fig. 22

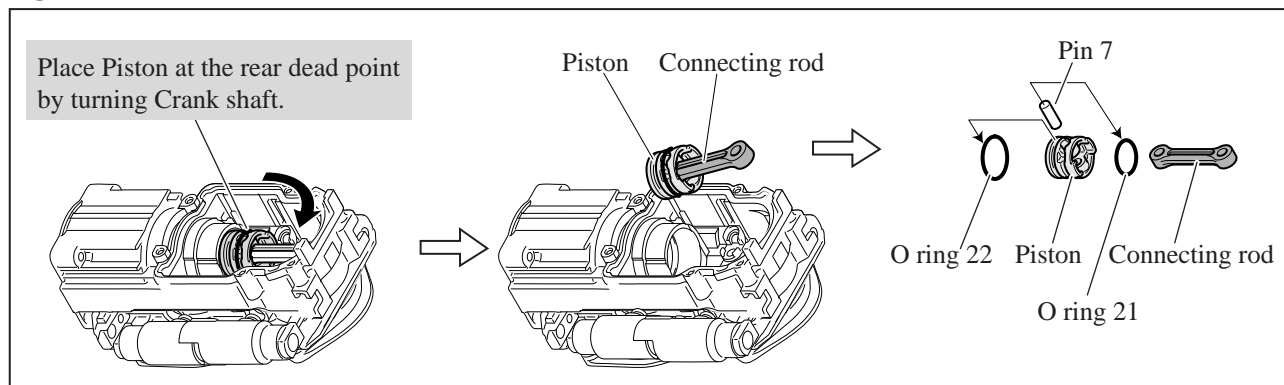

ASSEMBLING

Do the reverse of the disassembling steps.

Note:

- When assembling Cylinder 28.5 to Crank housing complete;
 - Do not forget to install two diameter 30 O rings and Ring spring 32 as illustrated in Fig. 23.
 - Use arbor press to insert the Cylinder into Crank housing complete if No.1R213 and No.1R350 are not available.
- Do not forget to put Ring 33 on Cylinder 28.5 when locking the Cylinder to Crank housing complete with Ring spring 31. (Fig. 18)

Fig. 23

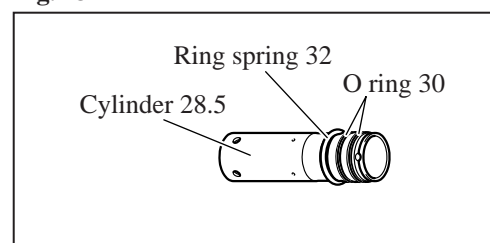

[3] -4. Motor and Gear Section

DISASSEMBLING

- From Crank housing complete, remove Crank housing cover (Fig. 6) and Handle (Fig. 14).
It is not necessary to remove Change lever and Crank cap cover in this step.
- After removing Rear cover, disconnect the connector of Lead unit from Controller. Then remove each two 4x14 Tapping screws that fasten Controller and Cord clamp base to Motor housing. Cord clamp base can now be removed. (Fig. 24)
- Remove Controller from Motor housing by levering up with screwdriver. Then move the spiral spring of Brush holder unit off Carbon brush, and pull out Carbon brush to disconnect from Armature's commutator. (Fig. 25)

Fig. 24

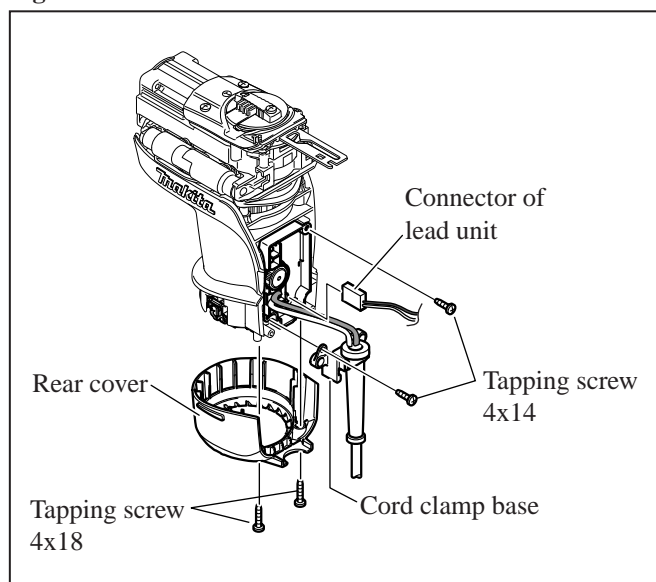
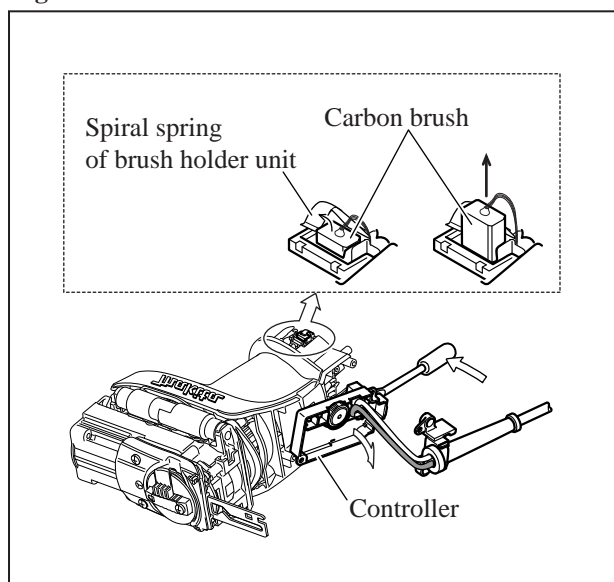

Fig. 25



► **Repair**

[3] DISASSEMBLY/ASSEMBLY

- 4) Remove Hex nut M6 by turning counterclockwise with impact driver while fixing Fan securely with gloved hand, then remove Flat washer 6 from Armature shaft. **(Fig. 26)**
- 5) In case of **HR4010C/HR4011C**;
Referring to **[3] -5. Active Dynamic Vibration Absorber** (page), remove two Active dynamic vibration absorbers.

Fig. 26

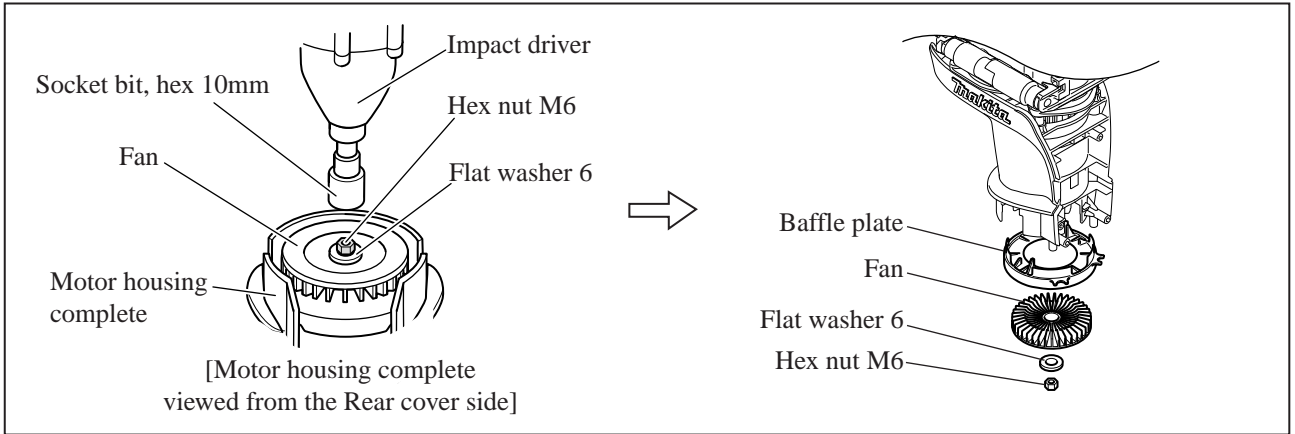

- 6) Separate Motor housing complete by removing four 5x25 Tapping screws, then tapping the commutator end of Armature shaft with plastic hammer. Then separate Gear housing complete from Crank housing complete. At this time, be careful not to lose Flat washer 10 of Crank shaft because it can remain in Gear housing complete. **(Fig. 27)**

Fig. 27

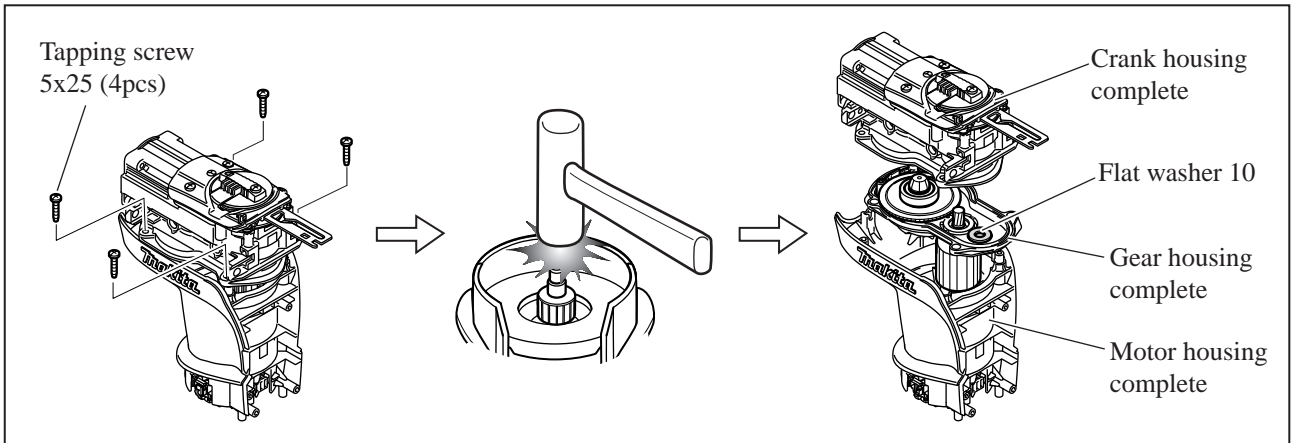

- 7) Remove Armature from Gear housing cover with Gear extractor, large (No.1R045) and Center attachment (No.1R346). **(Fig. 28)**

Fig. 28

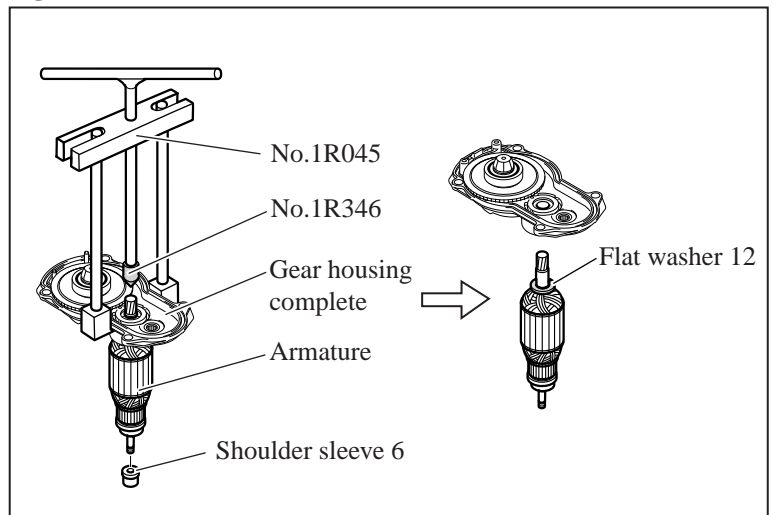

► **Repair**

[3] DISASSEMBLY/ASSEMBLY

8) Remove Torque limiter assembly from Gear housing complete by tapping the edge of Gear housing complete with plastic hammer. If Torque limiter assembly remains on Crank housing complete, remove by tapping the edge of Crank housing complete. (Fig. 29)

Fig. 29

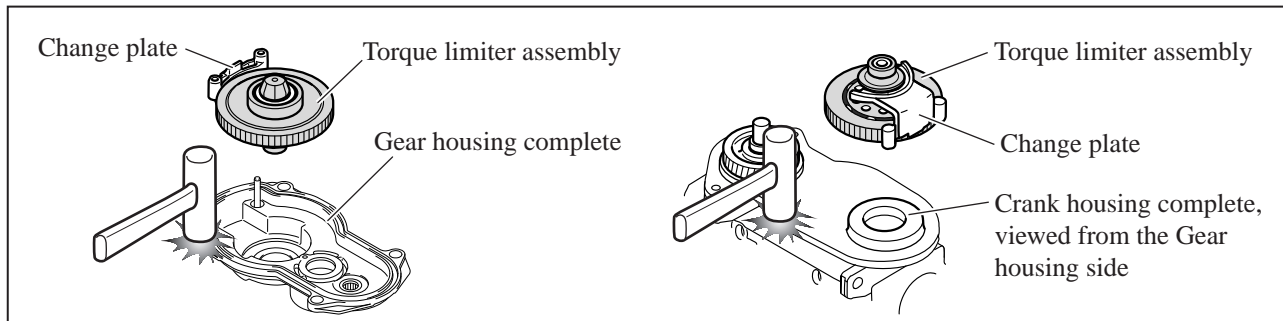

9) After removing Change plate from Torque limiter assembly, remove Ball bearing 6904LLU and Ball bearing 608DDW from Torque limiter assembly using Bearing extractor (No.1R269). (Fig. 30)

10) Then remove Cup washer, Conical compression spring 19-27 and Driving flange from Torque limiter. (Fig. 31)

Important: Never try to disassemble Torque limiter because it cannot be reassembled once disassembled.

Fig. 30

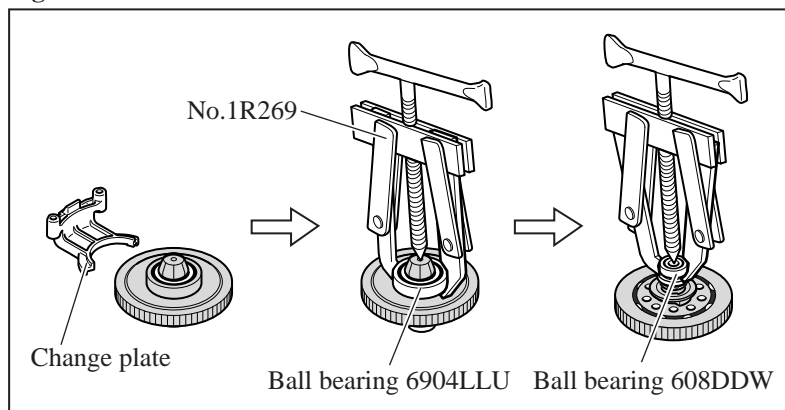
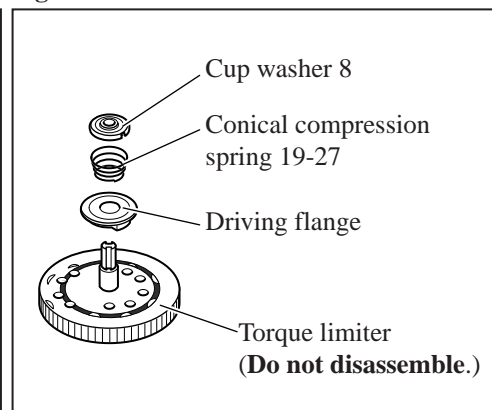

Fig. 31



11) When Crank shaft still remains in Crank housing complete, remove by first rotating Crank shaft till the crank pin is placed at the rear dead point, then tapping Crank housing complete with plastic hammer. (Fig. 32)

12) The assembly of Crank shaft and Helical gear 38 can be disassembled using arbor press as illustrated in Fig. 33.

Fig. 32

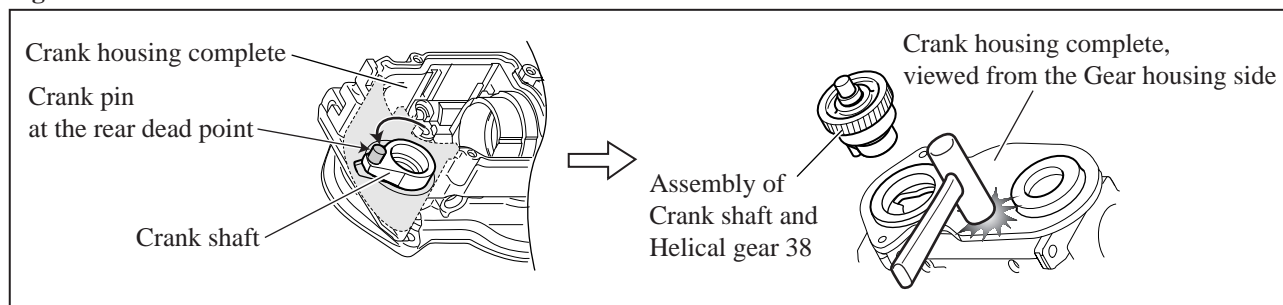
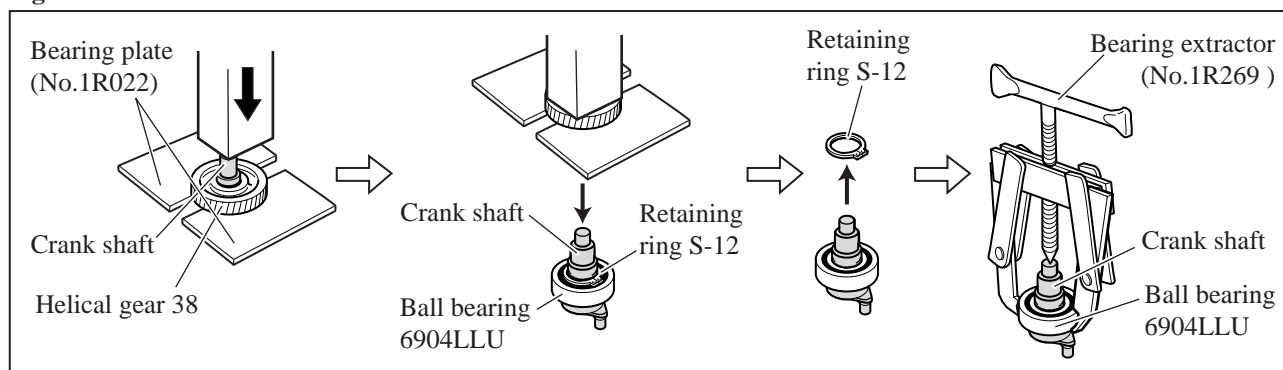

Fig. 33



► **Repair**

[3] DISASSEMBLY/ASSEMBLY

ASSEMBLING

Do the reverse of the disassembling steps. Remember the following notes.

Note 1. When Assembling Torque Limiter Assembly

- 1) Conical compression spring 19-27 and Driving flange are not reversible when assembled to Torque limiter. As illustrated in **Fig. 34**, be sure to assemble so that;
 - Driving flange: the flanged end faces the Conical compression spring side.
 - Conical compression spring: the smaller diameter end faces the Driving flange side.
 - Cup washer 8: the side with a raised center faces the Ball bearing 608DDW side.
- 2) When assembling Cup washer 8 to Straight bevel gear 7 of Torque limiter; first insert Cup washer 8 through Straight bevel gear 7 with the notch in the Cup washer aligned with the groove on the Straight bevel gear. Then while pressing down Cup washer 8, turn the Cup washer 90 degrees. Now Cup washer 8 is pre-fastened to Straight bevel gear 8, then securely fastened by press-fitting Ball bearing 608DDW with arbor press. (**Fig. 35**)

Fig. 34

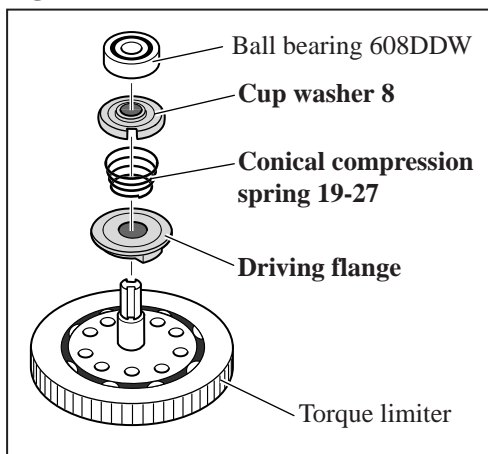
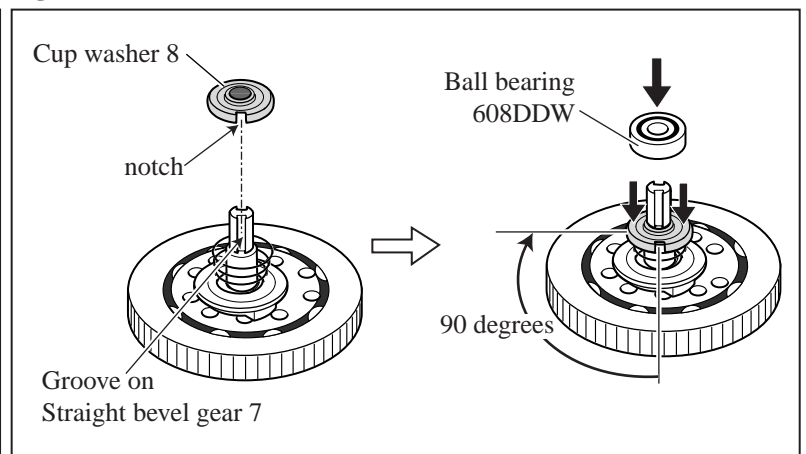

Fig. 35



Note 2. When Installing Torque Limiter Assembly on Gear Housing Complete

- 1) Set Change plate between Driving flange and the largest gear of Torque limiter. (**Fig. 36**)
- 2) Do not forget to insert Compression springs through the pins on Gear housing complete. (**Fig. 37**)
- 3) The Change plate installation side should be placed on the Compression spring installation side of Gear housing complete. (**Fig. 37**)

Fig. 36

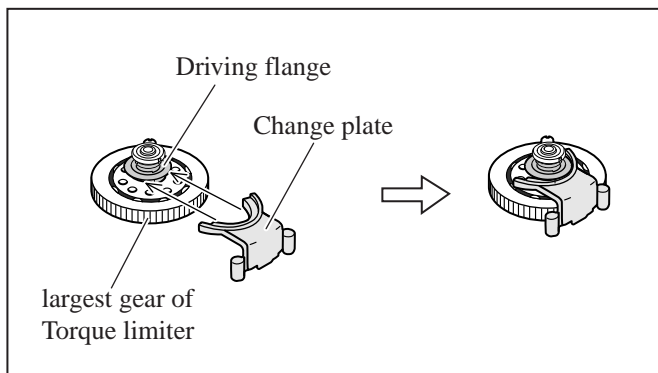
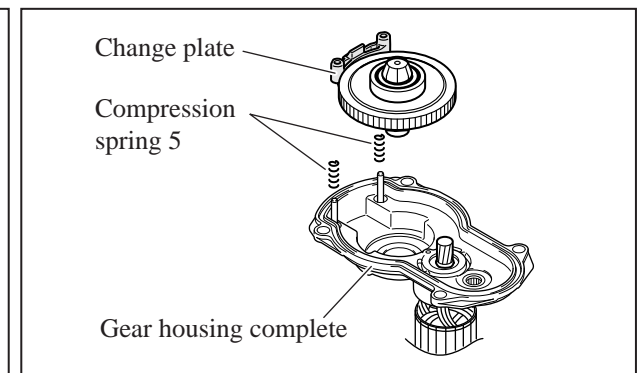
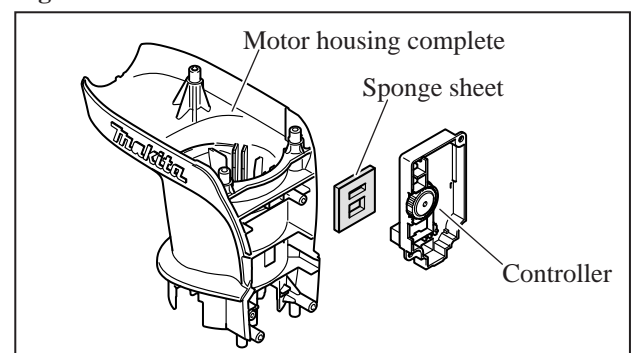

Fig. 37



Note 3. Do not forget to put Sponge sheet between Controller and Motor housing complete. (Fig. 38)

Fig. 37



► **Repair**

[3] DISASSEMBLY/ASSEMBLY

[3] -5. Active Dynamic Vibration Absorber of HR4010C and HR4011C

DISASSEMBLING

- 1) Remove Crank housing cover and Handle. (Fig. 38)
- 2) See Fig. 39.

Through the hole on the Absorber holder of Crank housing complete, insert Phillips screwdriver into the hole on one end of the Active dynamic vibration absorber, and push Spring guide (inner part of the Absorber) with the screwdriver.

The Spring guide will tilt to be locked inside the Absorber, and this end of the Absorber is now released from Crank housing complete.

Then do the same on the other end of the Absorber.

- 3) Now the Absorber can be levered off from Crank housing complete using a slotted screwdriver (Fig. 40)

Fig. 38

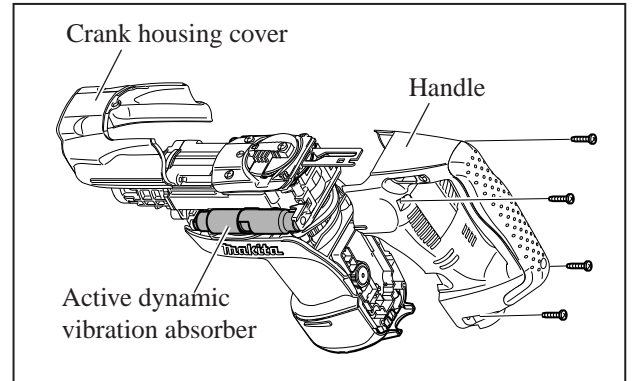

Fig. 39

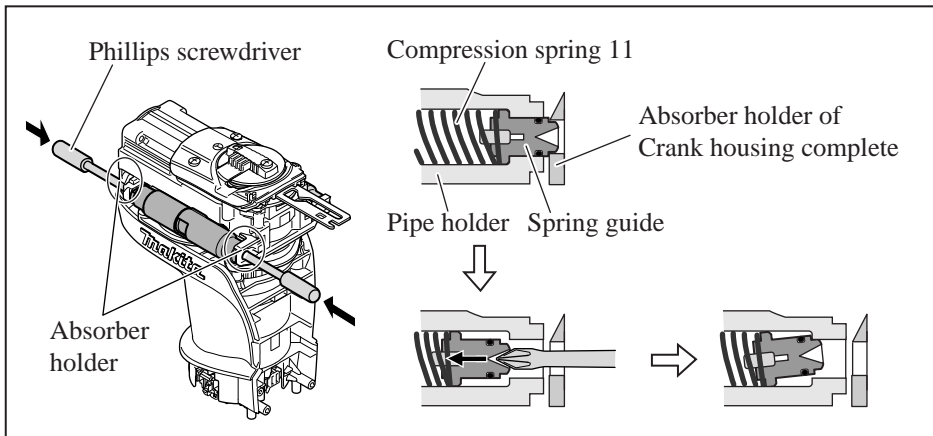
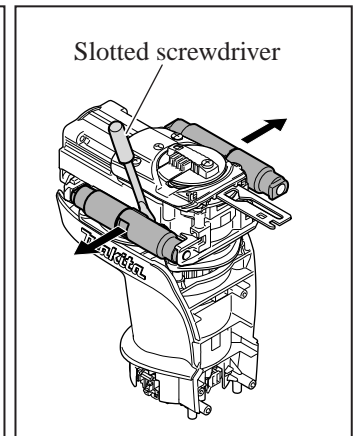

Fig. 40



- 4) As illustrated in Fig. 41, Pipe holders can now be separated by turning Pipe holders while pushing strong toward each other.
- 5) Now Active dynamic vibration absorber can be disassembled as illustrated in Fig. 42.

An Active dynamic vibration absorber uses two each except for the following parts: Pipe 16/ 1pc, Counter weight/ 1pc, O ring 8/ 4pcs.

Fig. 41

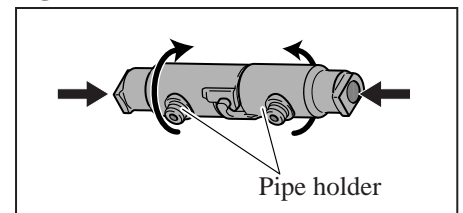
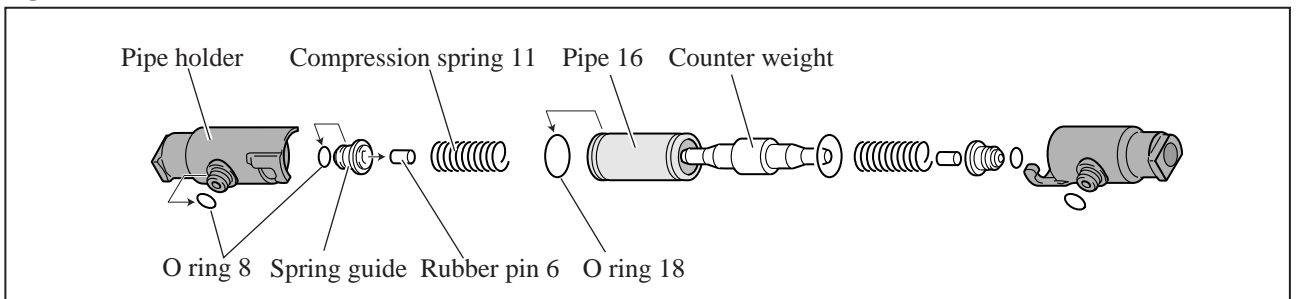

Fig. 42



ASSEMBLING

Do the reverse of the disassembling steps.

Note:

Do not forget to lock the Absorber in the Absorber holder of crank housing complete. (Fig. 39)

► Repair

[3] DISASSEMBLY/ASSEMBLY

[3] -6. Handle Section

HR4001C and HR4010C

(models with two selectable on-off switches)

DISASSEMBLING

- 1) See Fig. 43. After removing one 5x25 Tapping screw, Handle cover can be separated from Handle by levering off with a slotted screwdriver inserted between Handle and Handle cover- the portion designated by the circle in Fig. 43. main switch can now be replaced.
- 2) Separate Handle from Motor housing by removing four 5x25 Tapping screws.
By unscrewing two 4x14 Tapping screws, Controller and Power supply cord can now be replaced. (Fig. 44)

Fig. 43

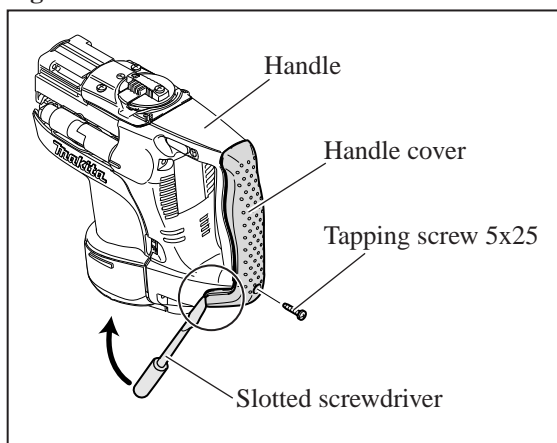
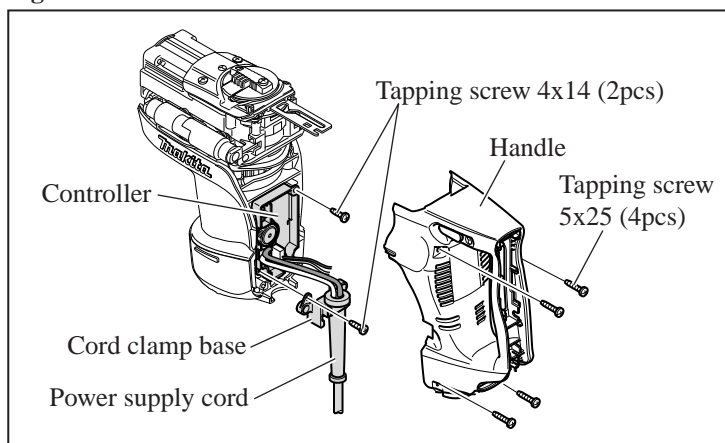
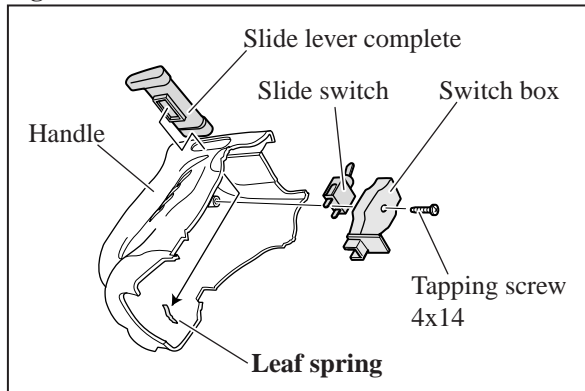

Fig. 44



- 3) See Fig. 45.
Slide lever complete, Switch box and Slide switch can be removed from Handle by unscrewing one 4x14 Tapping screw.
Note: Be careful not to lose Leaf spring.

Fig. 45



- 4) Remove Change lever and Crank cap cover from Crank housing. Control plate can now be removed. (Fig. 46)

Fig. 46

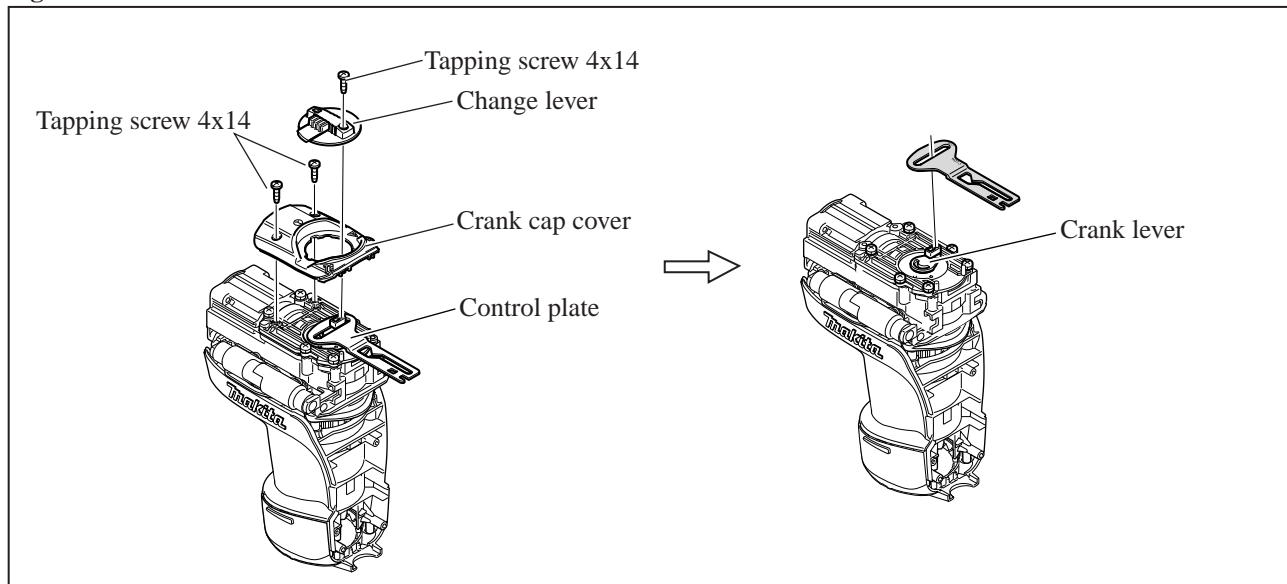

► Repair

[3] DISASSEMBLY/ASSEMBLY

[3] -6. Handle Section

HR4001C and HR4010C

(models with two selectable on-off switches)

ASSEMBLING

Do the reverse of the disassembling steps.

Note 1: Control plate is not reversible when fit on Crank lever. Be sure to install so that the side having embossed part number is placed on the Crank cap cover side. (Fig. 47)

Note 2: Do not forget to mount Leaf spring between Slide lever complete and Slide switch when assembling them to Handle. (Fig. 45)

Fig. 47

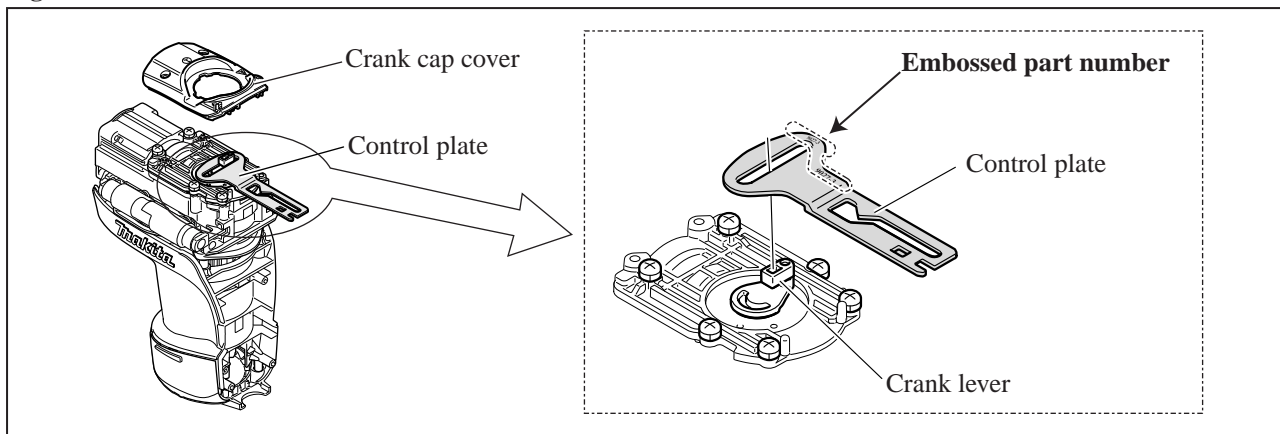

HR4011C

(model without two selectable on-off switches)

DISASSEMBLING

1) See Fig. 48. After removing one 4x18 Tapping screw, Handle cover can be separated from Handle by levering off with a slotted screwdriver inserted between Handle and Handle cover- the portion designated by the circle in Fig. 48. main switch can now be replaced.

2) Separate the assembly of Handle and Handle base from Motor housing by removing four 5x25 Tapping screws. By unscrewing two 4x14 Tapping screws, Controller and Power supply cord can now be replaced. (Fig. 49)

Fig. 48

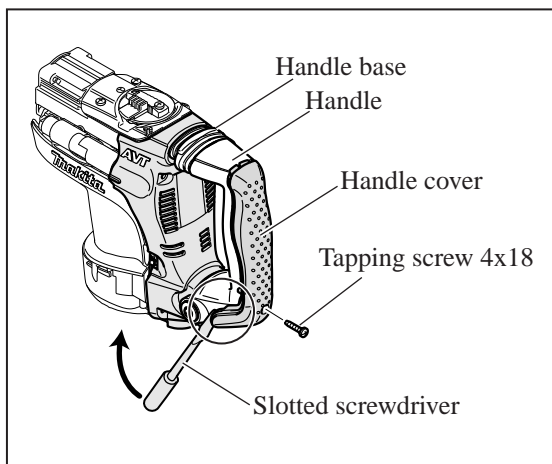
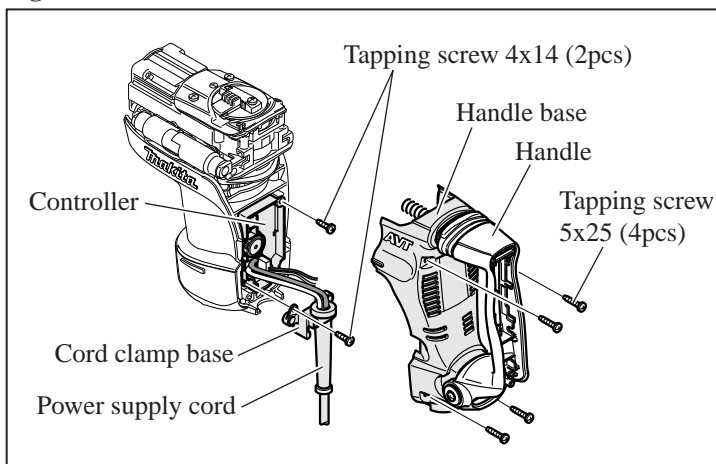

Fig. 49



ASSEMBLING

Do the reverse of the disassembling steps.

► **Repair**

[3] DISASSEMBLY/ASSEMBLY

[3] -6. Brush Holder Unit

DISASSEMBLING

- 1) Referring to 1) to 5) of [3] -4, disassemble the Motor section.
Note: Before proceeding to the next step, be sure to disconnect Controller from Brush holder unit. (Fig. 27)
- 2) Brush holder unit can now be separated from Motor housing by removing four 4x18 tapping screws, (Fig. 50)

ASSEMBLING

Following the steps described below, assemble Brush holder unit to Motor housing (Fig. 51):

- 1) Place Brush holder unit so that the connector to Controller on the unit faces toward the Motor housing side and toward the Handle side.
- 2) Align the top surface line of the base portion of Brush holder unit with the guiding line on the inside surface of Motor housing.
- 3) Keeping the base portion of Brush holder unit parallel to the guiding line, push straight into Motor housing.
- 4) Then fasten Brush holder unit to Motor housing with four 4x18 Tapping screws, and the terminals on Brush holder unit is now connected with the receptacles on Field.

Note: Be careful not to tilt Brush holder unit in any direction when pushing into Motor housing. Inserting tilted Brush holder unit into Motor housing will result in deformation of the receptacles on Field and the terminals on Brush holder unit.

Fig. 51

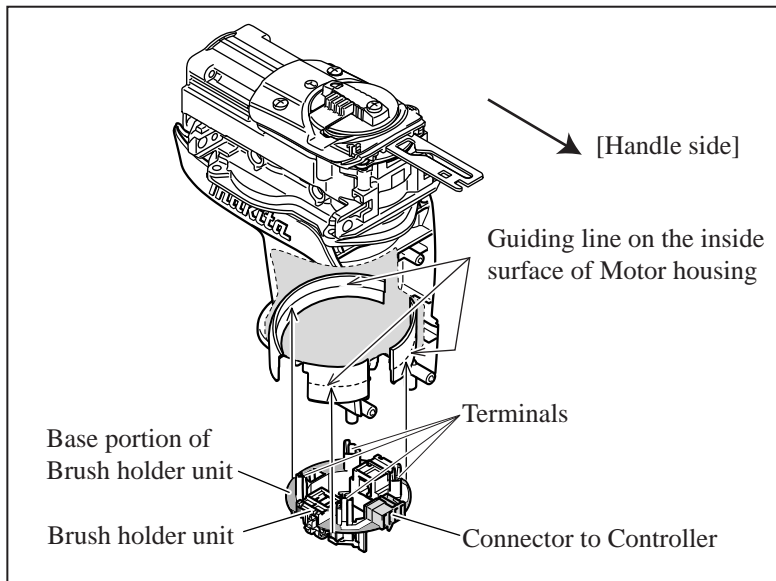

[3] -7. Field

Field cannot be installed in place on Motor if Brush holder unit is already assembled in place.

When assembling Field to Motor housing, therefore, make sure that Brush holder unit is not installed on Armature.

Fig. 50

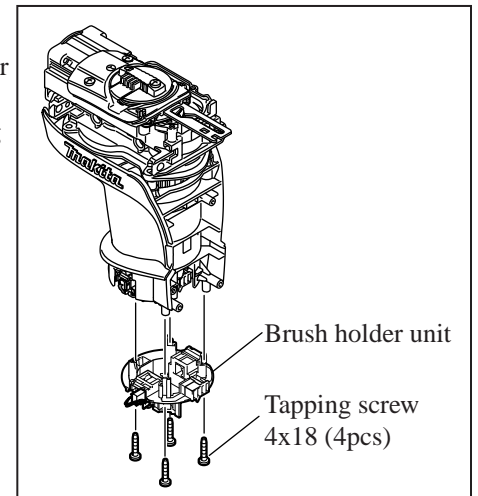
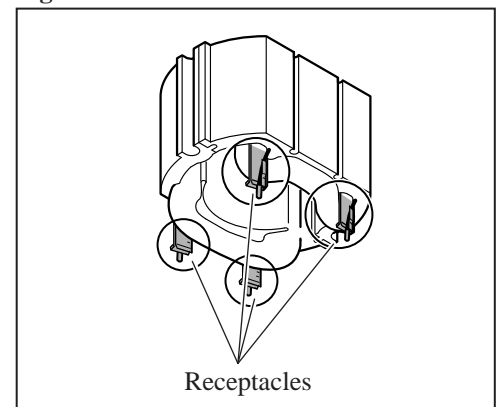

Fig. 52



► **Repair**

[4] Maintenance Program

When replacing carbon brush, it is recommended to replace the parts listed in the table below at the same time for longer service life of the machine. **(Fig. 53)**

Item No.	Description	Note
1	Tool holder cap	
24	O ring 20	Apply Makita grease R No.00 after mounting to Impact bolt.
25	Fluoride ring 25	
26	X ring 18	
32	O ring 22	Apply Makita grease R No.00 after mounting to Striker.
38	O ring 22	Apply Makita grease R No.00 after mounting to Piston.

Fig. 53

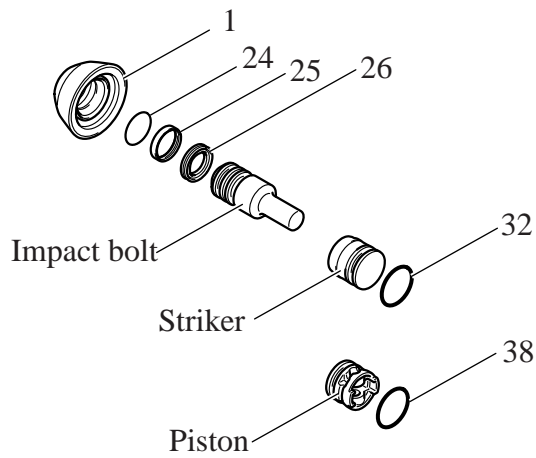

► **Circuit diagram**

Fig. 54

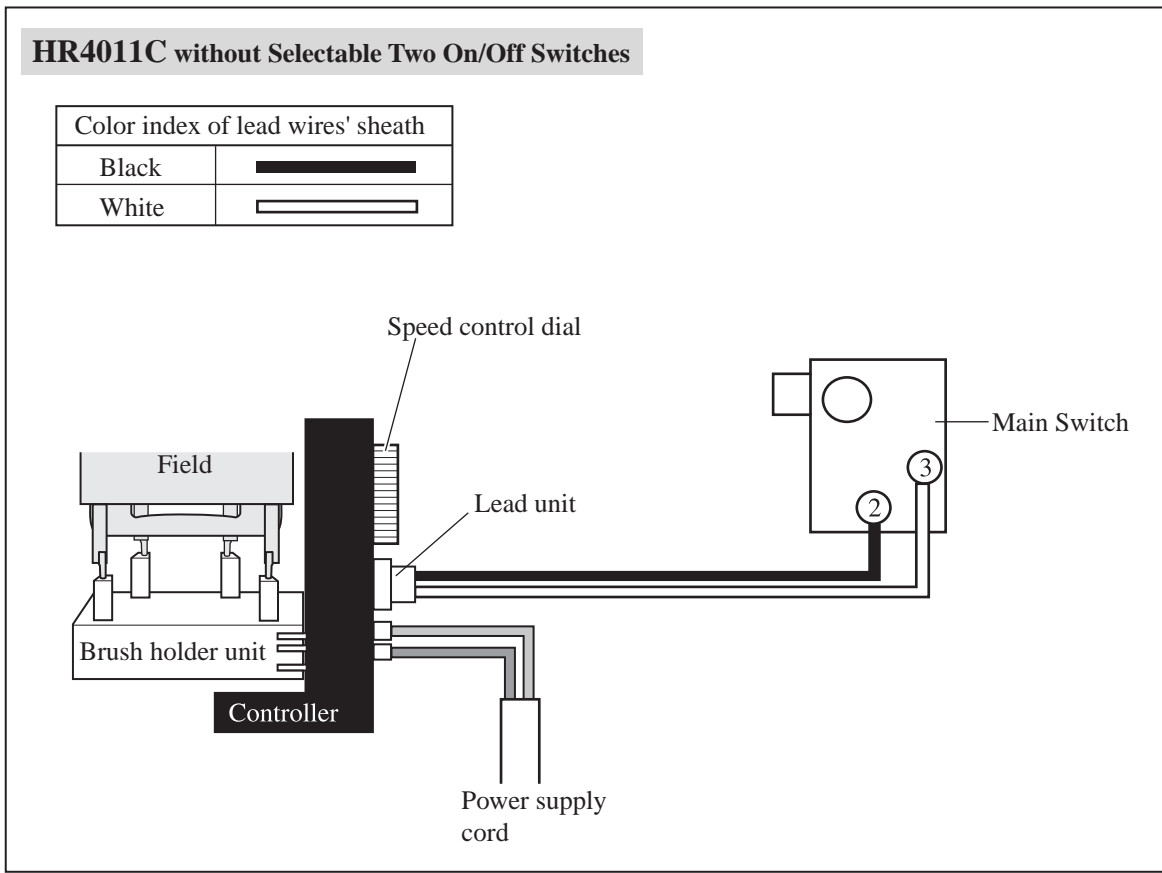
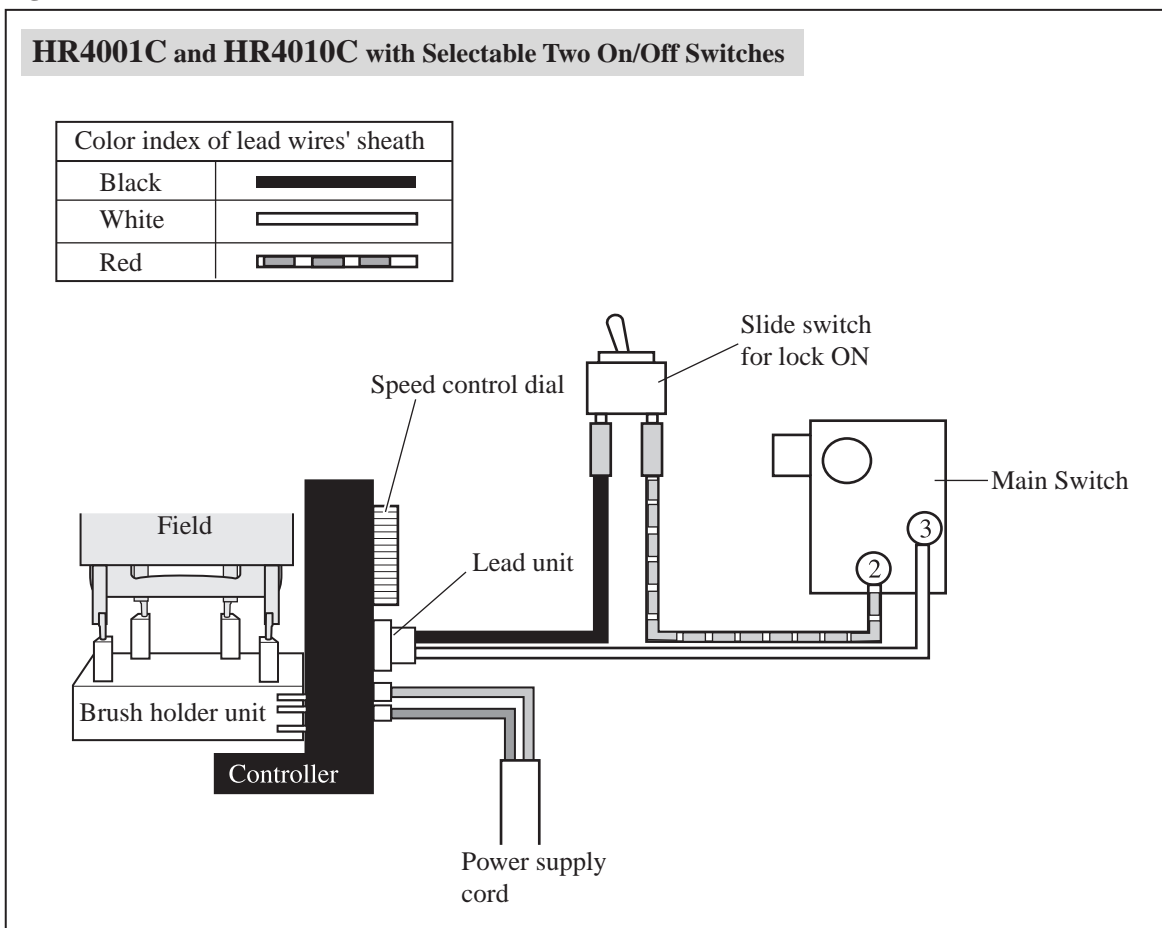

Fig. 55



► **Wiring diagram**

[1] In Handle

Lead Wires from Main switch

Fix with the lead wire holders of Handle and Switch holder. (Fig. 56)

Fig. 56

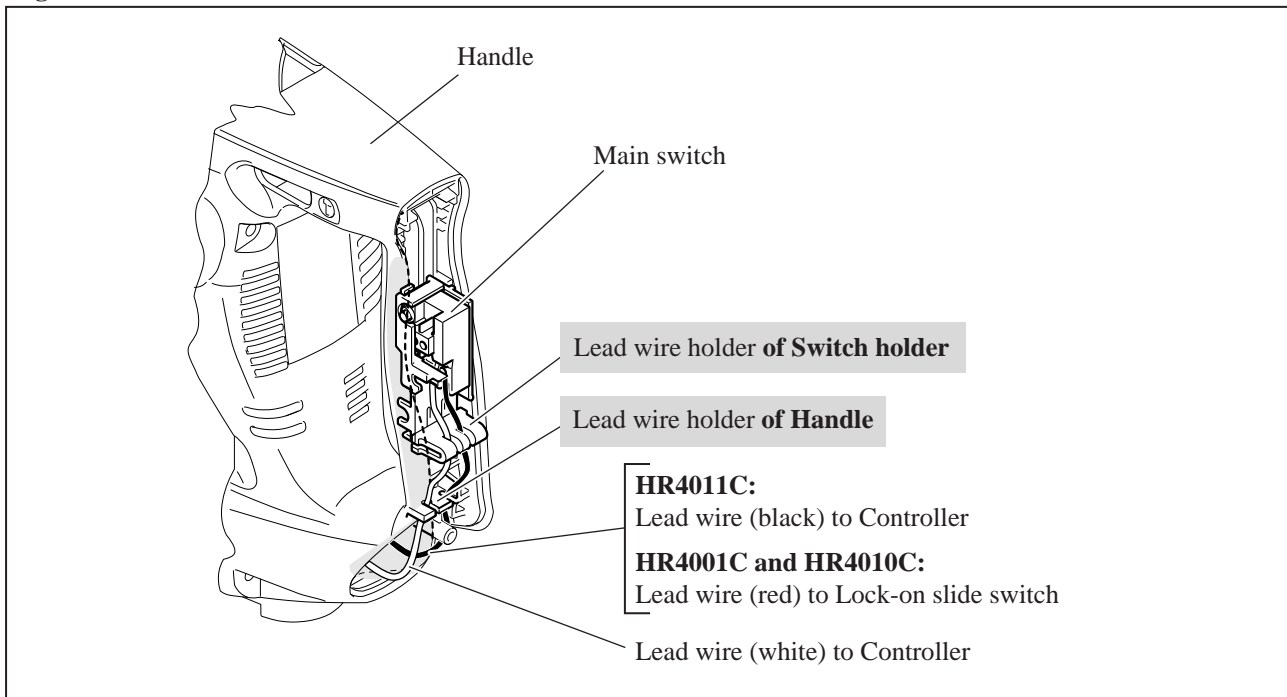

Lead Wires to Lock-On Slide Switch (HR4001C and HR4010C)

Fix with the lead wire holders on the inside surface of Handle. (Fig. 57)

Fig. 57

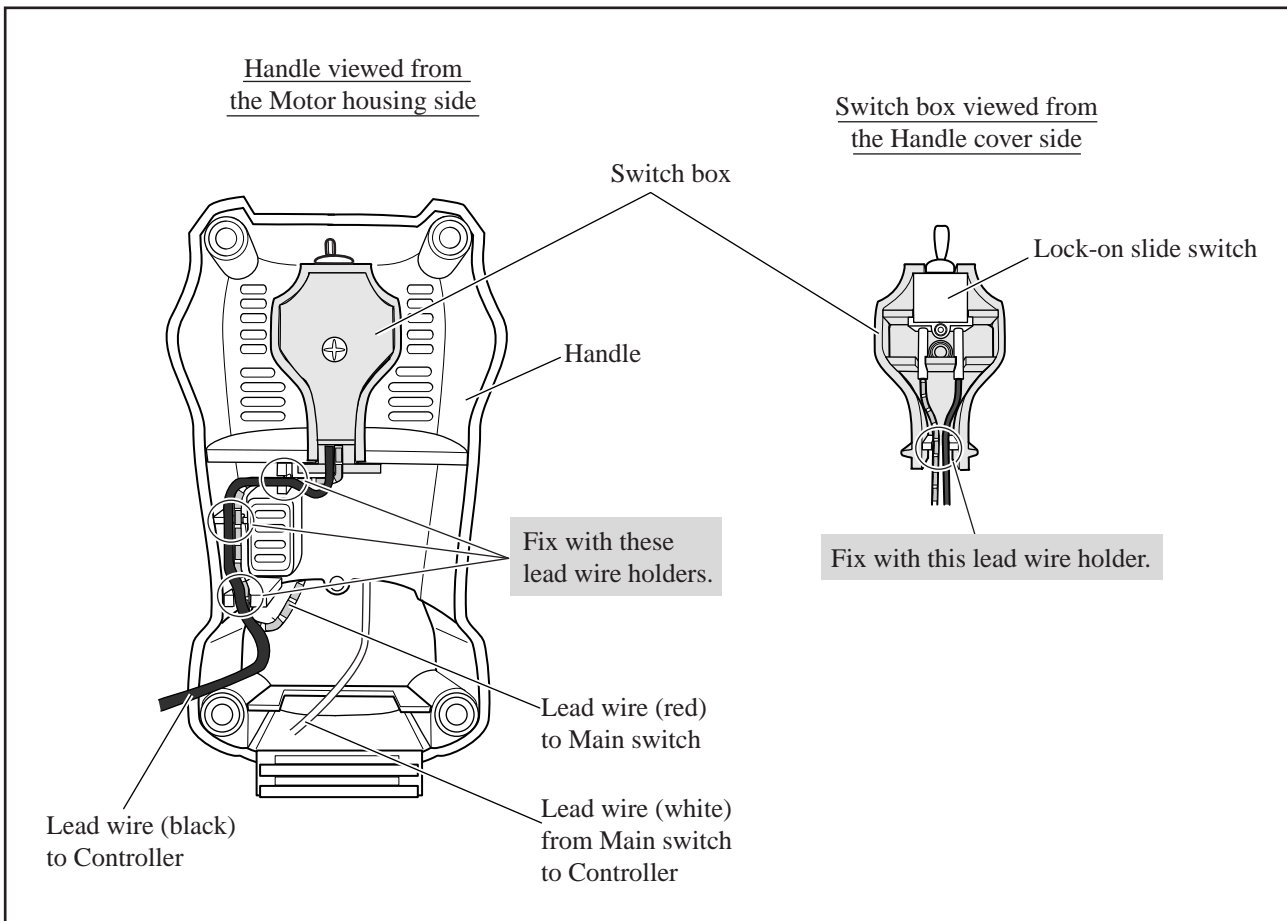

► Wiring diagram

[2] In Motor Housing

Lead Wires of Power Supply Cord

When assembling Handle to Motor housing, be careful not to pinch at the circled portion in **Fig. 58**.

Fig. 58

