

2-Speed Hammer Drill

HP2050

REPAIR MANUAL



► Repair

< 1 > Lubrication

Apply MAKITA grease N No.1 to the following portions marked with black triangle to protect parts and machine from unusual abrasion. See Fig. 1.

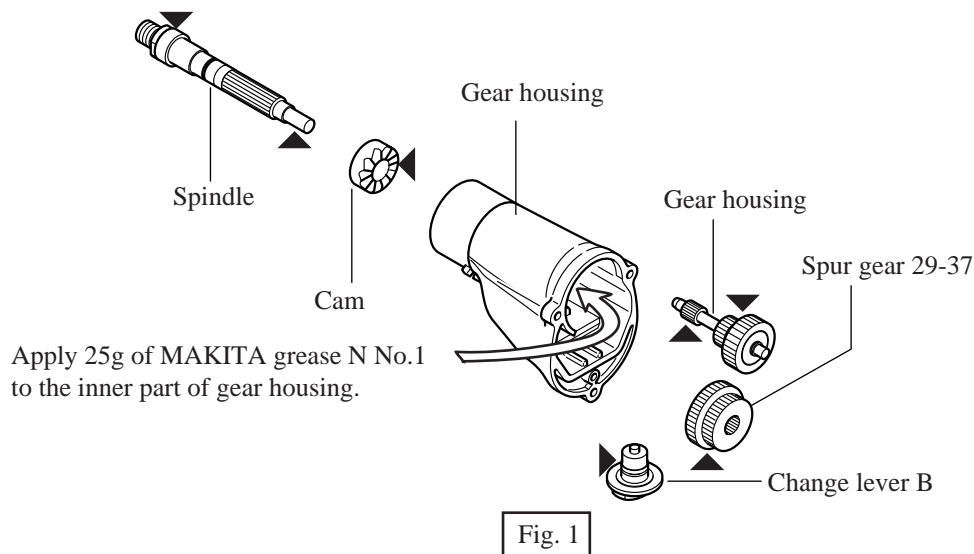

< 2 >Assembling and disassembling

(1) Disassembling drill chuck See Fig. 2.

1. Hold the flat portion of spindle with No.1R139 "drill chuck extractor" which is fixed with vise.
2. Insert No.1R298 "hex wrench" into drill chuck and grip it firmly with drill chuck.
3. Turn No.1R298 "hex wrench" anti-clockwise, with No.1R223 "torque wrench" to which No.1R224 "ratchet head" is attached. Then, drill chuck can be disassembled from spindle.

In case of broken drill chuck, it may be impossible to grip hex wrench with drill chuck.
If so, firmly grip drill chuck with pipe wrench. And turn the pipe wrench anti-clockwise.
So, the drill chuck can be disassembled.

(2) Assembling drill chuck See Fig. 2.

1. Preset the torque level of No.1R223 "torque wrench" to 35.7N.m - 45.9N.m (350kgf.cm - 450kgf.cm).
2. Hold the flat portion of spindle with No.1R139 "drill chuck extractor" which is fixed with vise
3. Insert No.1R298 "hex wrench" into drill chuck and grip it firmly with drill chuck.
4. Turn No.1R298 "hex wrench" clockwise, with No.1R223 "torque wrench" to which No.1R224 "ratchet head" is attached. Then, drill chuck can be assembled to spindle.

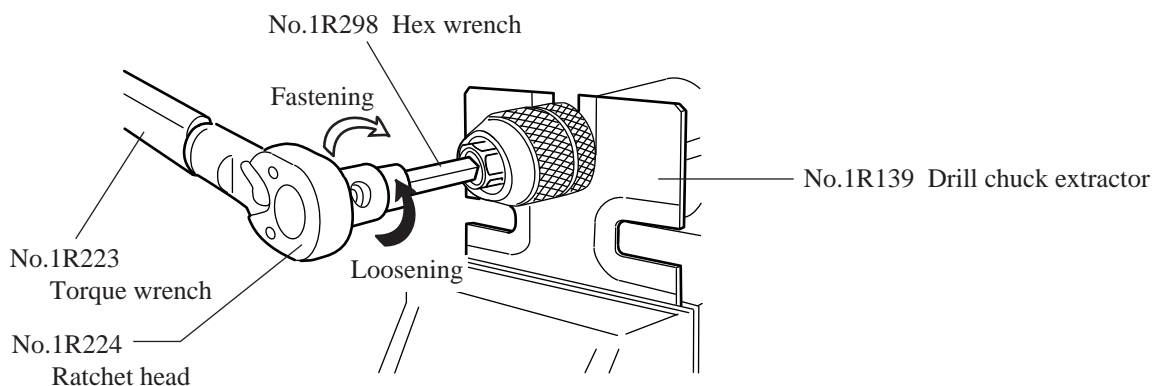

► Repair

(3) Disassembling gear section See Fig. 3.

1. Separate gear housing cover from gear housing.
2. Pull out lock plate.
3. Then change lever B, pin, rack 12 with change plate B and spur gear 29-37 can be disassembled from gear housing.

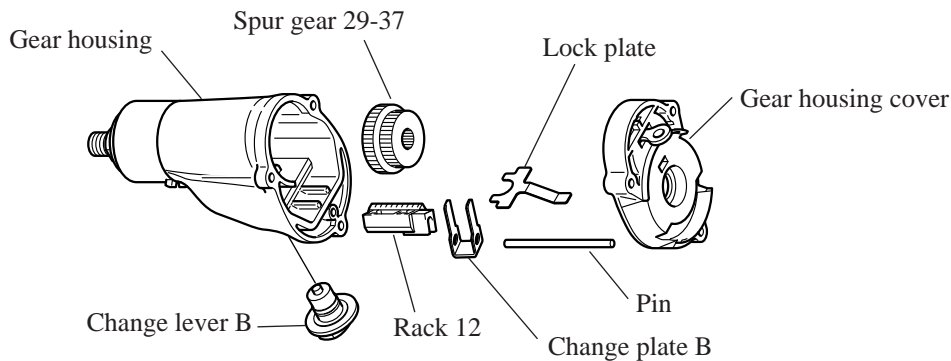

Fig. 3

(4) Assembling gear section

1. Assemble the spindle section to gear housing as illustrated Fig. 4 below.

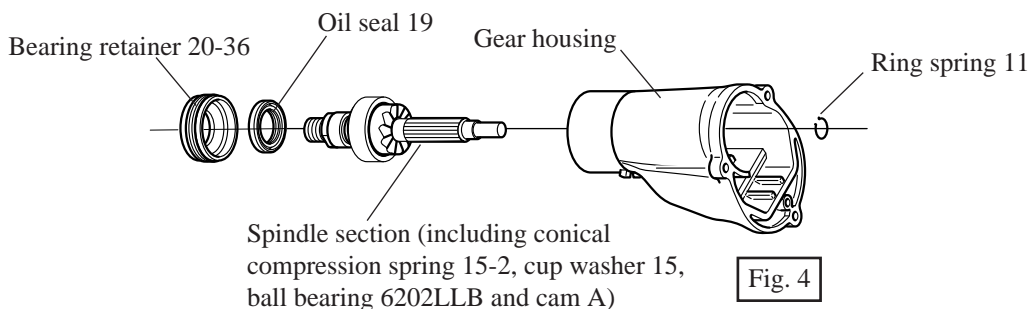

Fig. 4

When assembling bearing retainer 20-36 and oil seal 19, refer to "(6) Assembling bearing retainer 20-36 and oil seal 19" at page 5.

2. Insert change plate B into rack 12 as illustrated Fig. 5 right.

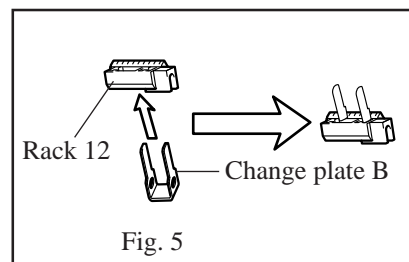

Fig. 5

3. Set the above assembled one to spur gear 29-37 as illustrated Fig. 6 right.

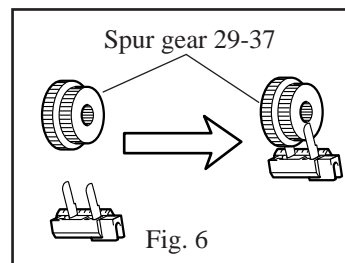

Fig. 6

4. Make sure that leaf spring is assembled in gear housing in advance. If not, assemble it. Assemble spur gear 29-37 to spindle and at the same time, assemble rack 12 w/ change plate B to gear housing as illustrated in Fig. 7 right.

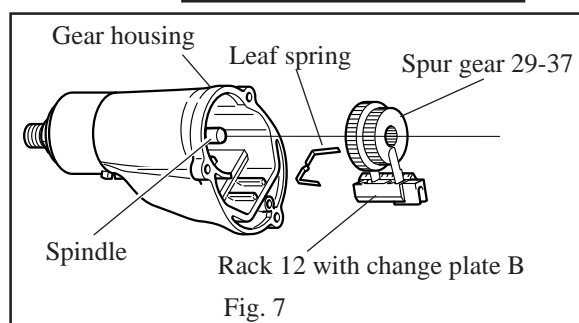
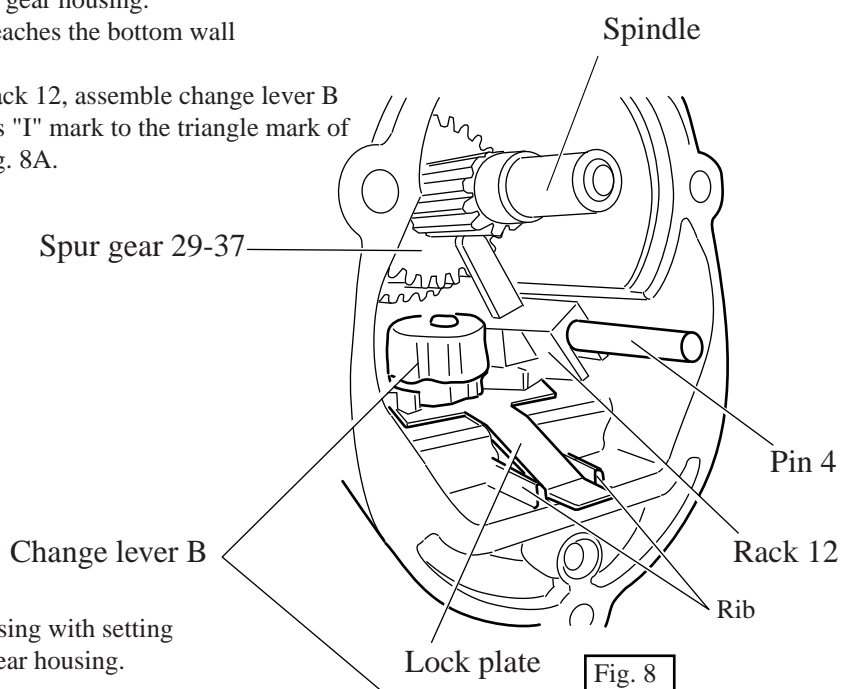

Fig. 7

► Repair

4. Insert pin 4 through rack 12 into gear housing.
And then, rush rack 12 until it reaches the bottom wall of gear housing. See Fig. 8.
Keeping the above position of rack 12, assemble change lever B to gear housing with aligning its "I" mark to the triangle mark of gear housing. See Fig. 8 and Fig. 8A.



5. Assemble lock plate to gear housing with setting its tail portion between ribs of gear housing.

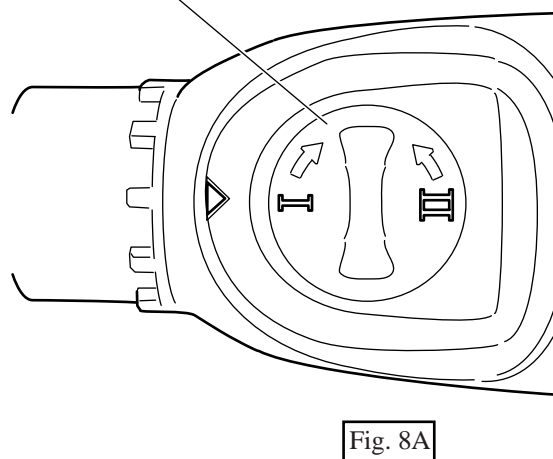

5. Assemble gear complete to the gear housing as illustrated in Fig. 9.

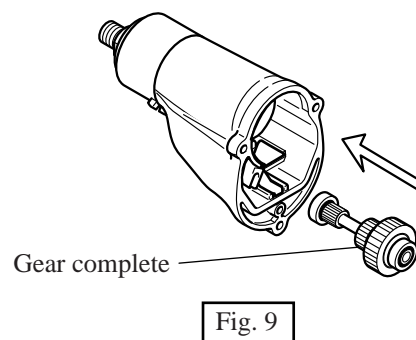

► Repair

(5) Disassembling bearing retainer 20-36 and oil seal 19

1. Remodel the top portion of No.1R292 "wrench for bearing retainer" by grinding, in order to fit it on the spindle head. See Fig. 10.

2. Turn 1R292 "wrench for bearing retainer" clockwise. Then bearing retainer 20-36 can be removed from gear housing. See Fig. 11. And then, take off oil seal 19 with flat head screwdriver.

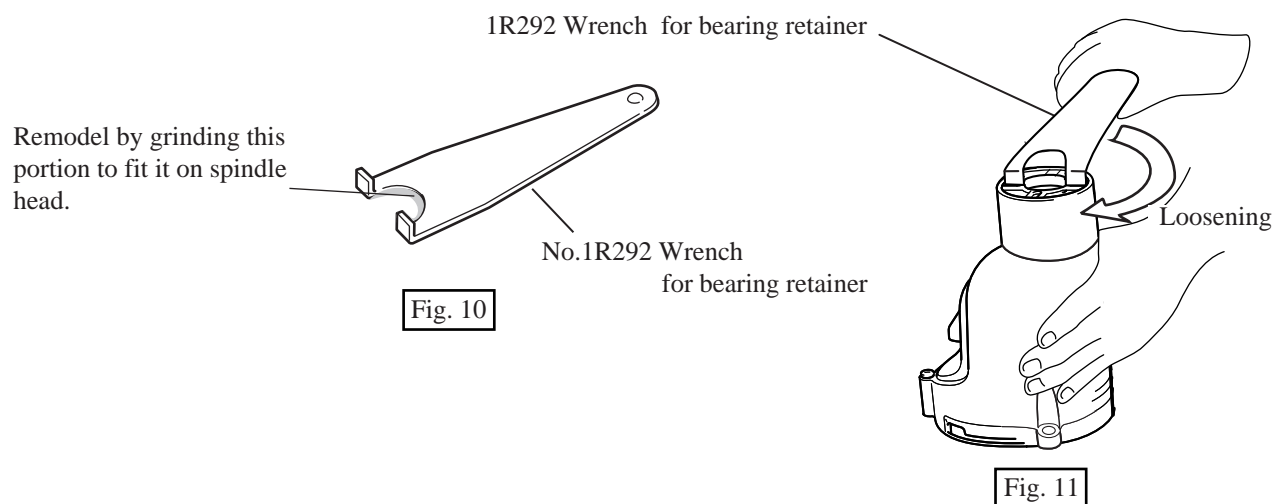

(6) Assembling bearing retainer 20-36 and oil seal 19

1. Apply MAKITA grease N No.1 to oil seal, and assemble oil seal 19 pressing with arbor press. See Fig. 12.

<Note in assembling>

Oil seal has to be always replaced with fresh one. Because it is easily deformed,when disassembling. Fig. 12

2. Assemble bearing retainer 20-36 with No.1R292 "wrench for bearing retainer" by turning it anti-clockwise. See Fig. 13.

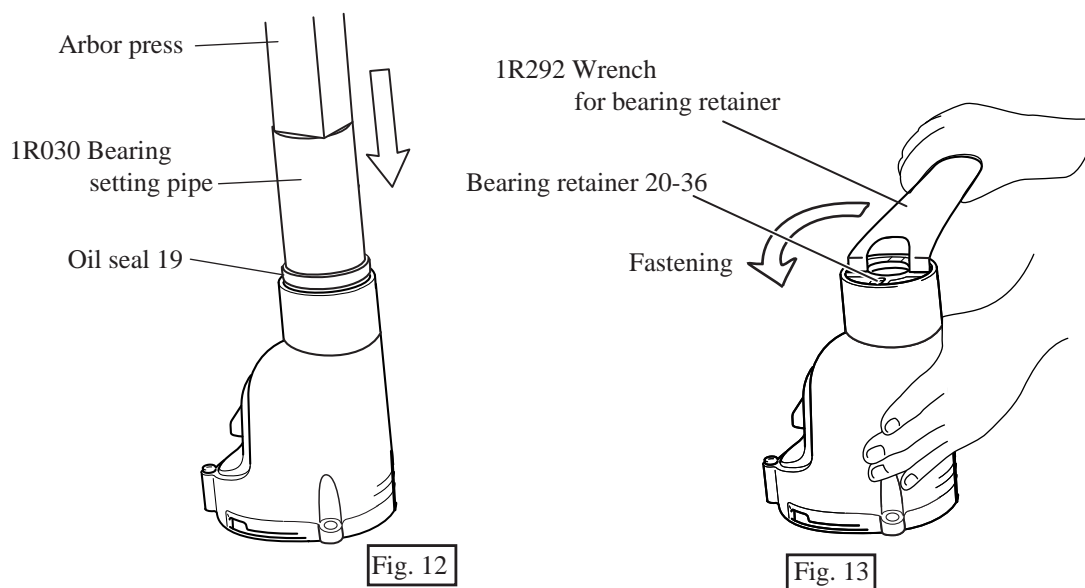

► Repair

(7) Disassembling cam A

1. After removing bearing retainer 20-36 and oil seal 19, disassemble ring spring 11 from spindle. And disassemble spindle section by pulling out from the drill chuck side of gear housing as illustrated in Fig 14.

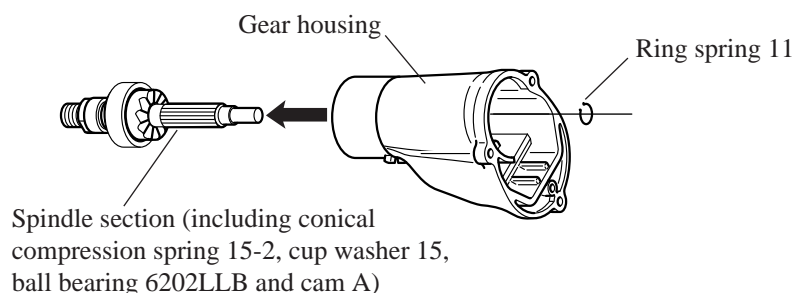

Fig. 14

2. Accept ball bearing 6202 LLB with 1R232 "pipe 30", and press spindle with arbor press. So, cam A, ball bearing 6202LLB, cup washer 15 and conical compression spring 15-24 can be separated from spindle as illustrated in Fig. 15.

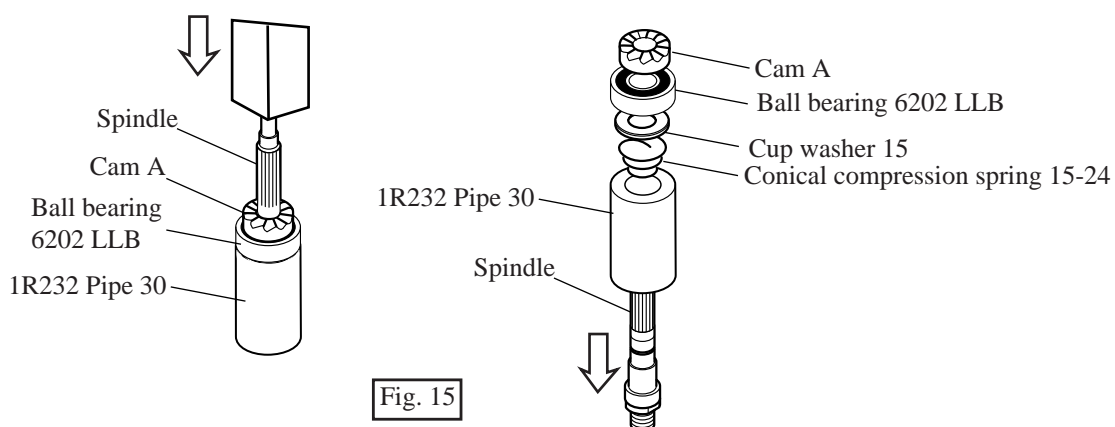

Fig. 15

(8) Assembling cam A

1. Assemble conical compression spring 15-24 and cup washer 15 to spindle. When assembling, they have to be assembled as illustrated in Fig. 16A.

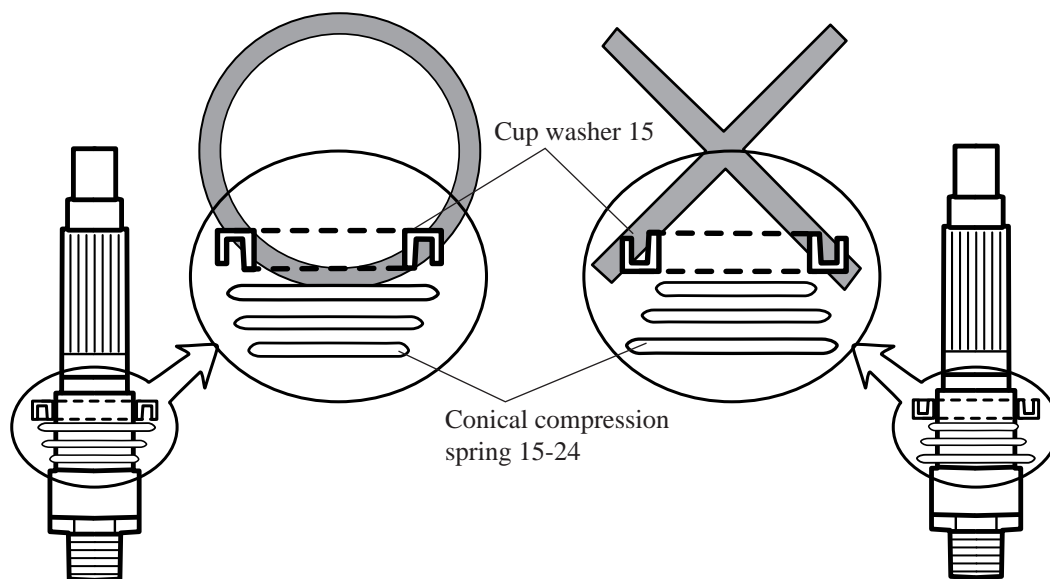

Fig. 16A

Fig. 16B

► **Repair**

2. Put the spindle on 1R035 "bearing setting plate" and assemble ball bearing 6202LLB and cam A to the spindle by pressing with arbor press as illustrated in Fig. 17.

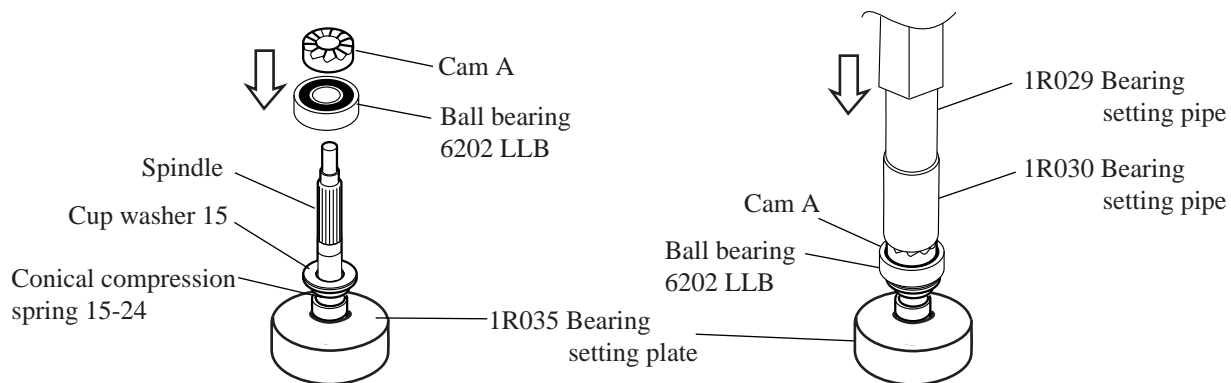

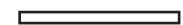





Fig. 17

► **Circuit diagram**

HP2050F and HP2051F (equipped with flash light)



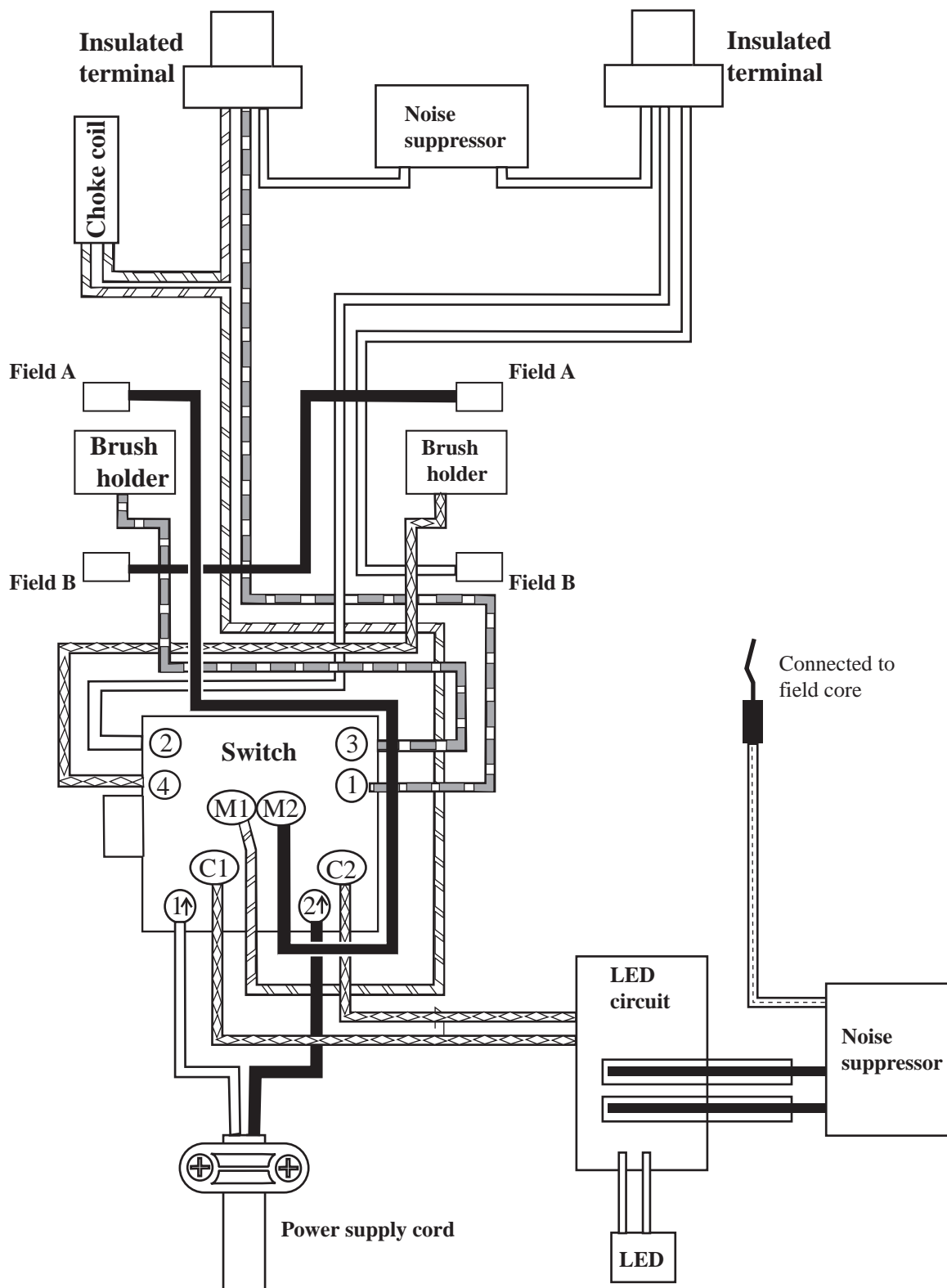

For Europe, High voltage area

Color index of lead wires	
Black	
White	
Red	
Orange	
Blue	
Transparent	



► **Circuit diagram**

HP2050F and HP2051F (equipped with flash light)
For other countries



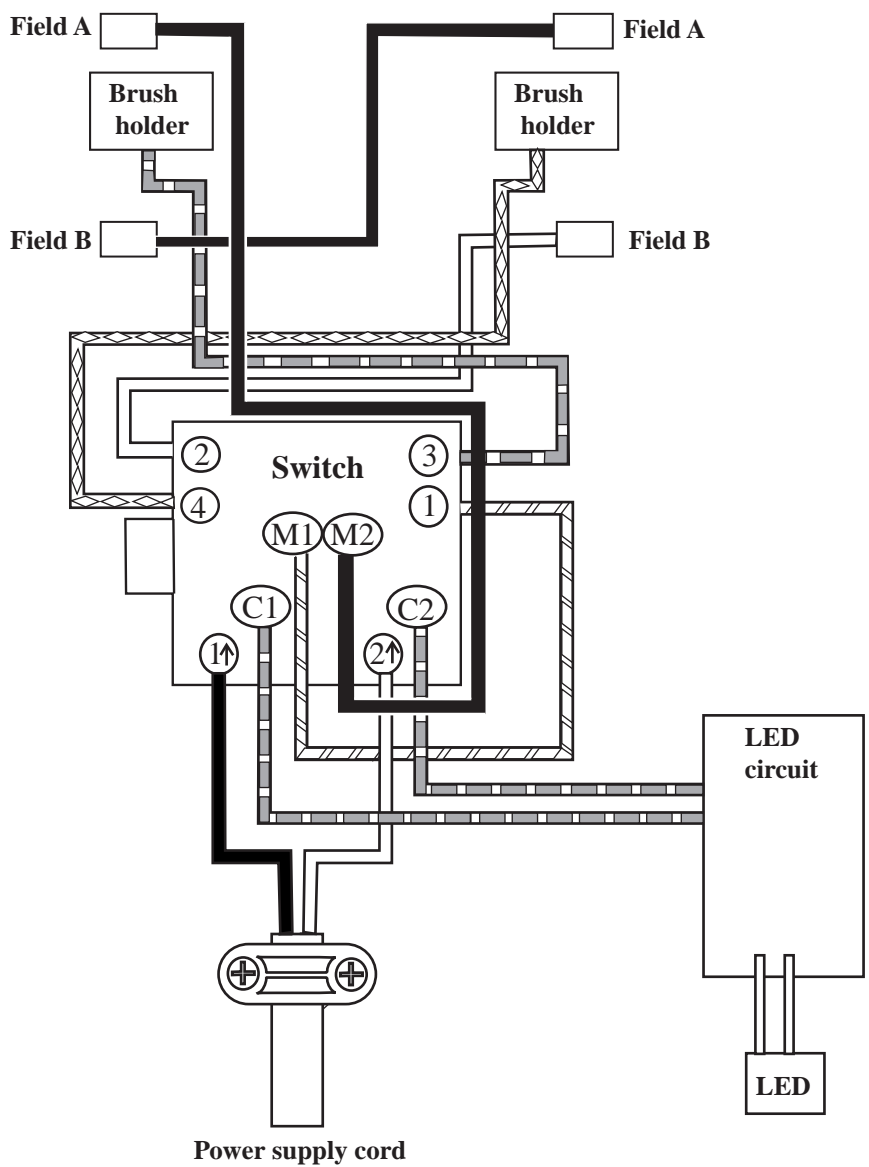



Color index of lead wires	
Black	
White	
Red	
Orange	
Blue	



► **Circuit diagram**

HP2050 and HP2051 (without flash light)





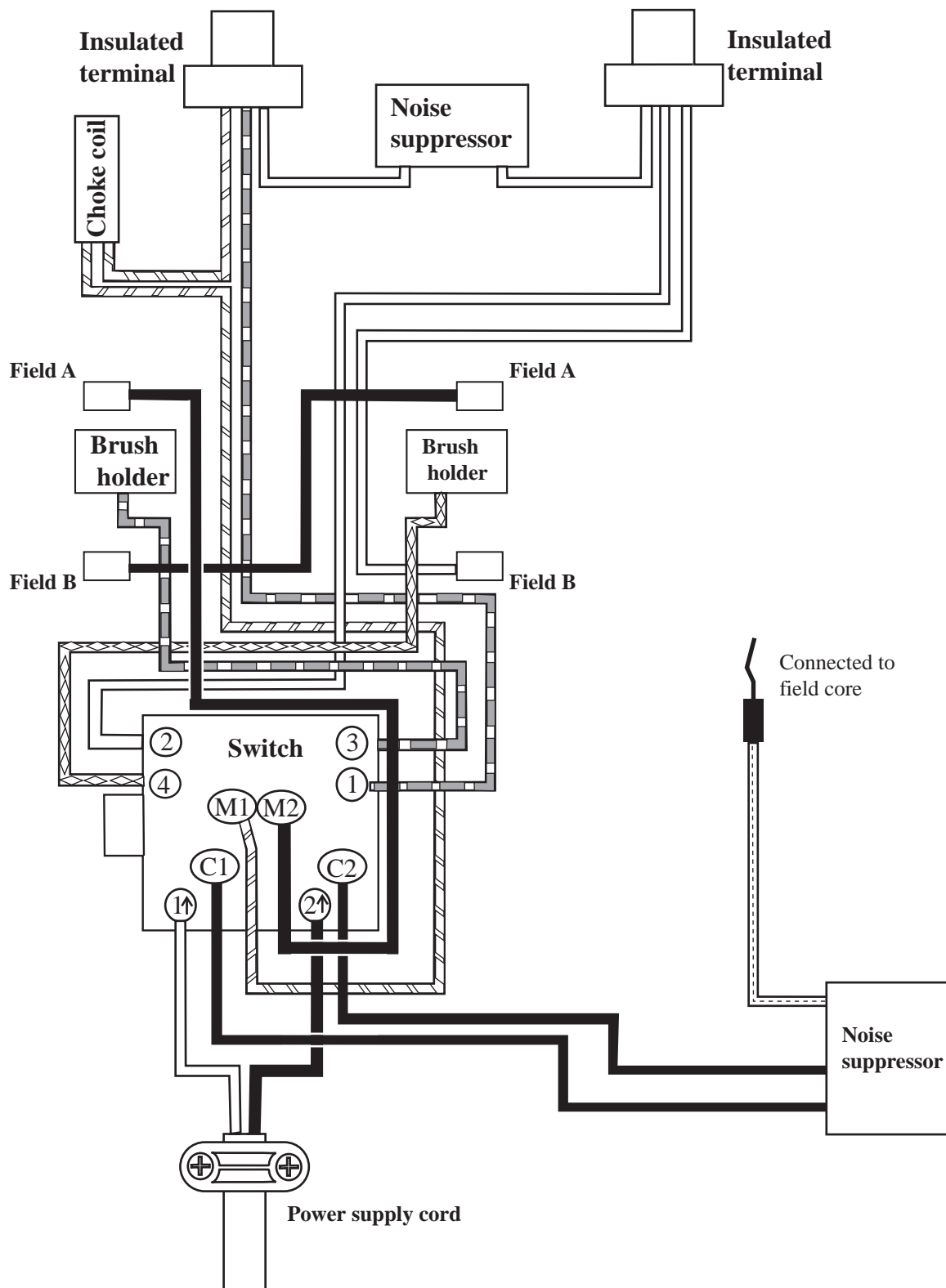

For Europe, High voltage area

Color index of lead wires	
Black	
White	
Red	
Orange	
Blue	
Transparent	



► **Circuit diagram**



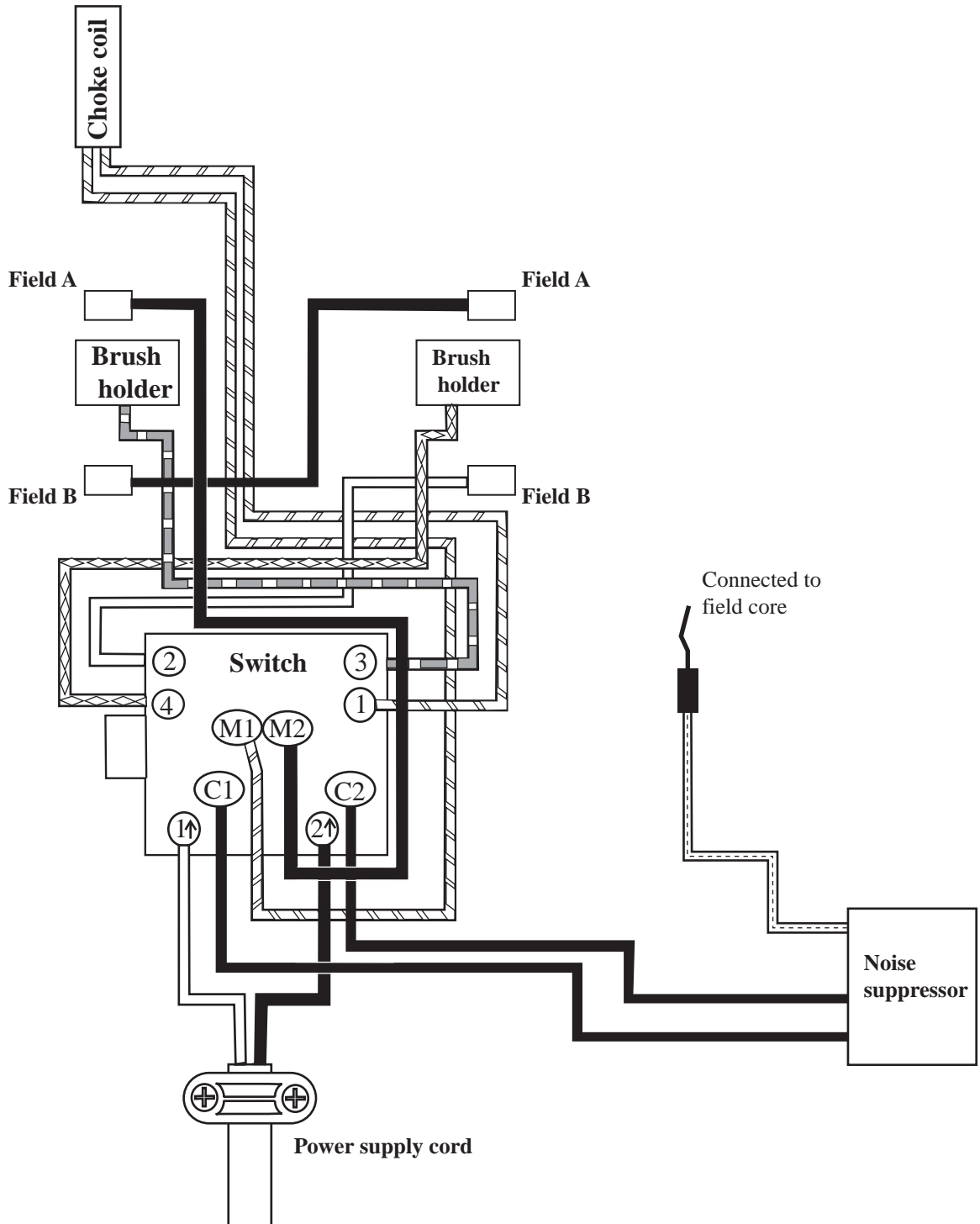

HP2050 and HP2051 (without flash light)
For Great Britain, low voltage

Color index of lead wires	
Black	
White	
Red	
Orange	
Blue	
Transparent	

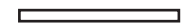

► **Circuit diagram**

HP2050 and HP2051 (without flash light)
For other countries

Color index of lead wires	
Black	
White	
Red	
Orange	
Blue	

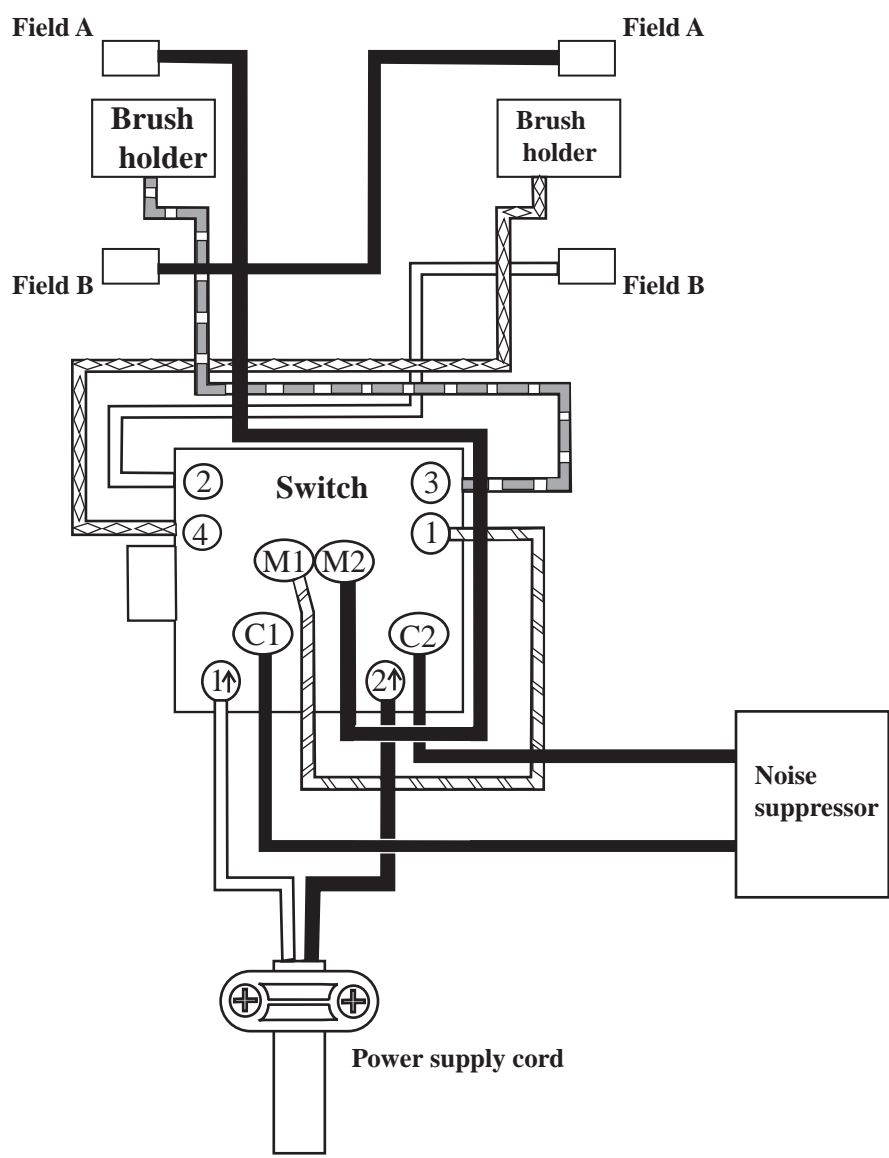

► **Wiring diagram**

HP2050F and HP2051F (equipped with flash light)

For Europe, High voltage area

The electrical parts marked with * have to be set in the illustrated position.

Fix the following lead wires with this lead holder.

- * Switch lead wire (red) for connecting to insulated terminal
- * Choke coil lead wire (orange) for connecting to insulated terminal

*** Choke coil**

Fix field lead wire (black) for connecting to switch, with lead holder.

Brush holder

Fix the following lead wires with this lead holder.

- * Switch lead wire (red) for connecting to brush holder
- * Lead wire (black) connecting field terminals A and B

Fix the lead wires passed through this portion, with lead holder

Noise suppressor

LED circuit

Fix the lead wires (white) of LED circuit, with lead holder. See Fig. A.

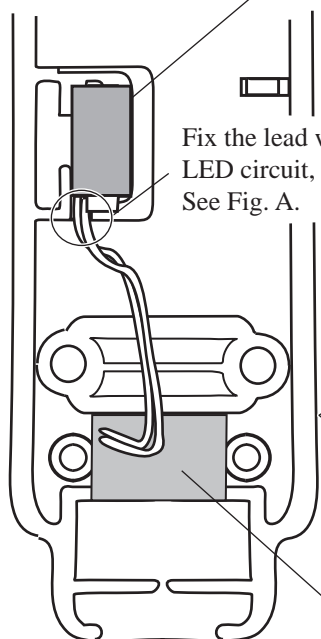

Fig. A

*** Noise suppressor**

*** Insulated terminal**

Fix the following lead wires with this lead holder.

- * Grounding lead wire (transparent) for connecting to field core
- * Field lead wire (white) for connecting to insulated terminal

Brush holder

Fix Lead wire (black) connecting field terminals A and B, with lead holder.

Fix the following lead wires with this lead holder.

- * Switch lead wire (blue) for connecting to brush holder
- * Field lead wire (white) for connecting to insulated terminal

Fix with lead holder the lead wires passed through this portion

Switch

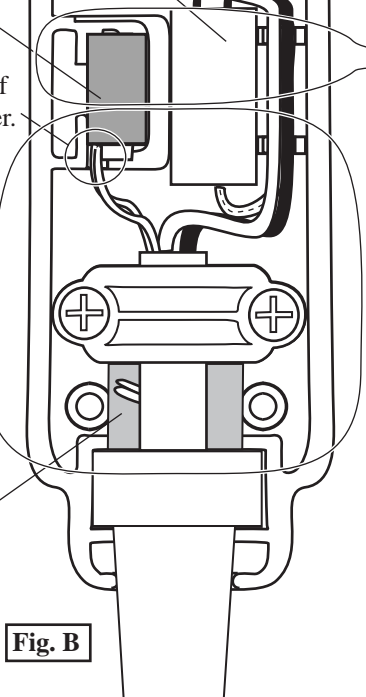

Fig. B

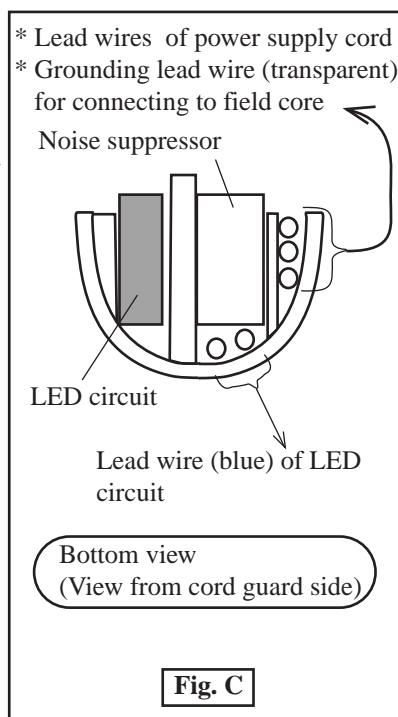
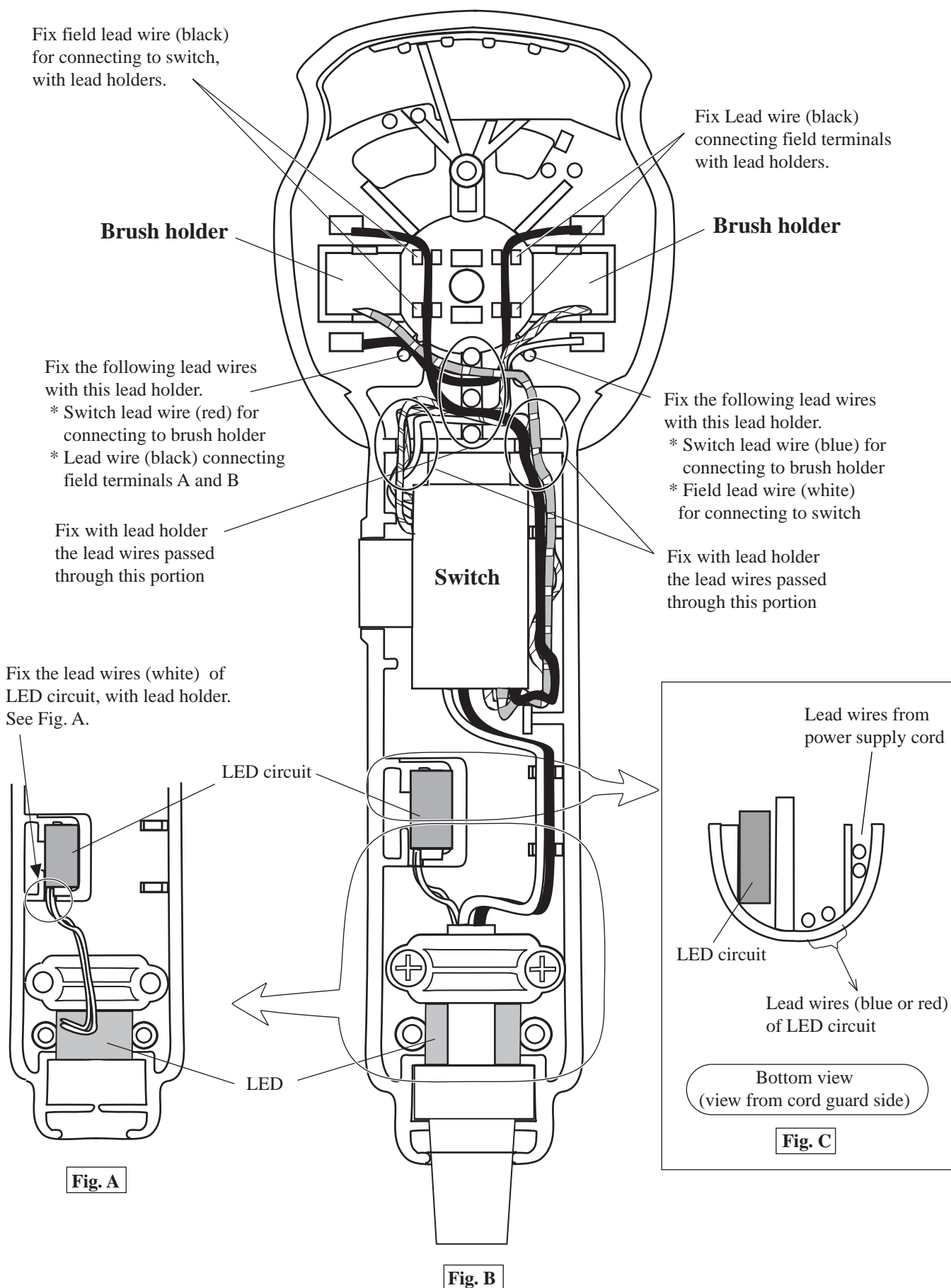

Fig. C

► **Wiring diagram**

HP2050F and HP2051F (equipped with flash light)
For other countries



► **Wiring diagram**

**HP2050 and HP2051 (without flash light)
For Europe, High voltage area**

The electrical parts marked with * have to be set in the illustrated position.

Fix the following lead wires with this lead holder.

- * Switch lead wire (red) for connecting to insulated terminal
- * Choke coil lead wire (orange) for connecting to insulated terminal

*** Choke coil**

Fix field lead wire (black) for connecting to switch, with lead holder.

Brush holder

Fix the following lead wires with this lead holder.

- * Switch lead wire (red) for connecting to brush holder
- * Lead wire (black) connecting field terminals A and B

Fix with lead holder the lead wires passed through this portion

Noise suppressor

*** Noise suppressor**

*** Insulated terminal**

Fix the following lead wires with this lead holder.

- * Grounding lead wire (transparent) for connecting to field core
- * Field lead wire (white) for connecting to insulated terminal

Brush holder

Fix Lead wire (black) connecting field terminals A and B, with lead holder.

Fix the following lead wires with this lead holder.

- * Switch lead wire (blue) for connecting to brush holder
- * Field lead wire (white) for connecting to insulated terminal

Fix with lead holder the lead wires passed through this portion

Switch

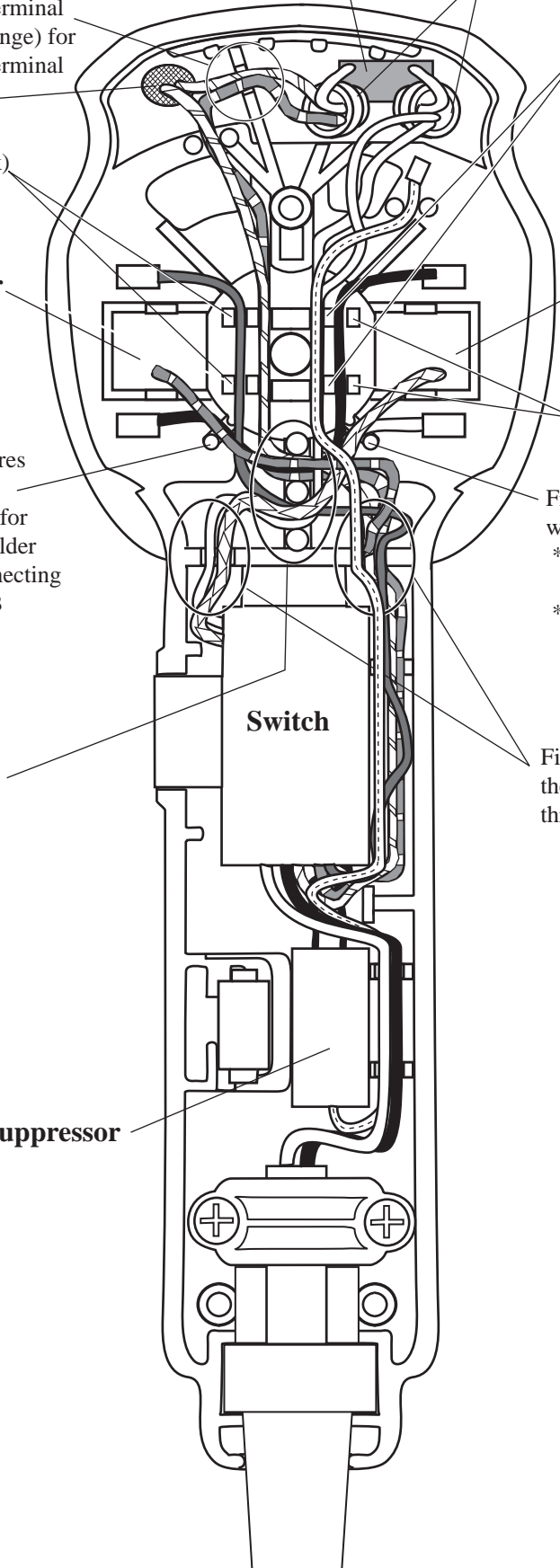

► **Wiring diagram**

HP2050 and HP2051 (without flash light)

For Great Britain, low voltage

Choke coil

Set choke coil in the position illustrated.

Fix choke coil lead wire (orange) with lead holders.

Fix field lead wire (black) for connecting to switch, with lead holder.

Fix grounding lead wire (transparent) for connecting to field core, with lead holder.

Brush holder

Brush holder

Fix the following lead wires with this lead holder.

- * Switch lead wire (red) for connecting to brush holder
- * Lead wire (black) connecting field terminals A and B

Fix Lead wire (black) connecting field terminals A and B, with lead holder.

Fix the following lead wires with this lead holder.

- * Switch lead wire (blue) for connecting to brush holder
- * Field lead wire (white) for connecting to switch

Switch

Fix with lead holder the lead wires passed through this portion

Fix with lead holder the lead wires passed through this portion

Noise suppressor

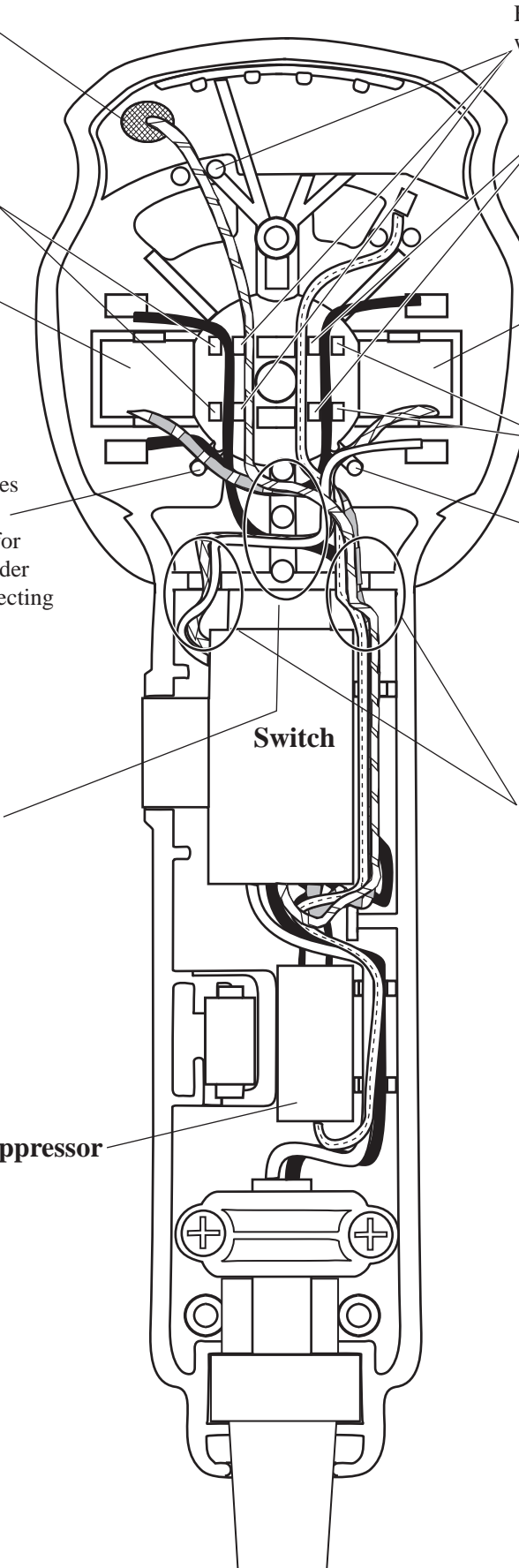

► **Wiring diagram**

HP2050 and HP2051 (without flash light)

For other countries

