

OFFICIAL USE
For ASC



IMPACT WRENCH

6906

REPAIR MANUAL



► Fastening power of machine

Always use the side grip (auxiliary handle) and firmly hold the tool by side grip and switch handle during operation. The proper fastening torque may depend on the kind or size of the bolt, the material of the workpiece, etc. The relation between fastening torque and fastening time is shown in the chart below.

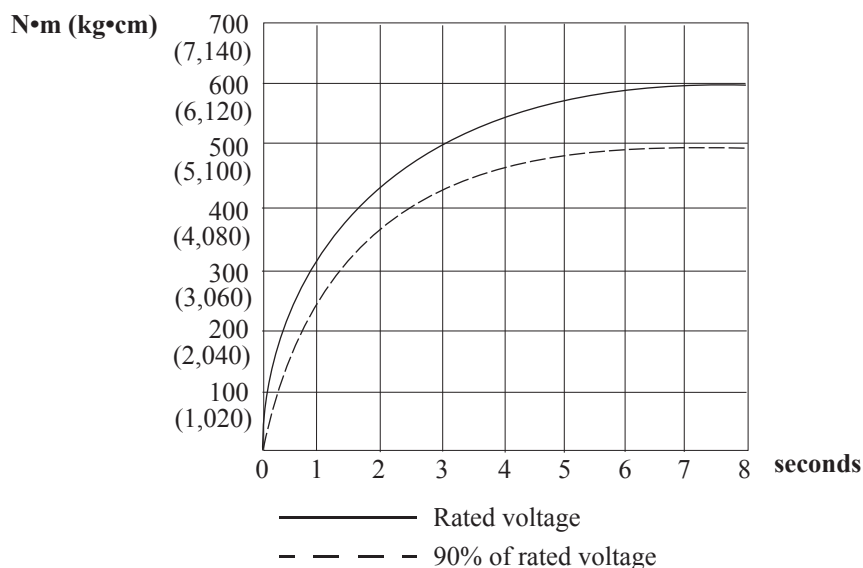

► Factors influencing on torque

A wide variety of factors exert a considerable influence on the fastening torque.

After fastening, therefore, always check the torque with a torque wrench.

Listed below are the five main factors:

1. Voltage
 - Voltage drop will cause a reduction in the fastening torque.
2. Socket
 - Failure to use the correct size socket will cause a reduction in the fastening torque.
 - A worn socket (wear on the hex end or square end) will cause a reduction in the fastening torque.
3. Bolt
 - Even though the torque coefficient and the class of bolt are the same, the proper fastening torque will differ according to the diameter of the bolt.
 - Even though the diameters of bolts are the same, the proper fastening torque will differ according to the torque coefficient, the class of bolt and the bolt length.
4. Use of the universal joint or the extension bar somewhat reduces the fastening force of the impact wrench. Compensate the reduction by fastening for a longer period of time.
5. The manner of holding the tool or the material of driving position to be fastened will affect the torque.

► **Disassembly order and notes**

1. First, remove Hammer case by loosening four Hex. socket head bolts.
2. Remove Retaining ring R75 with Retaining ring pliers, then press the top end of Anvil. The inner parts of Hammer case can now be removed.
3. Hammer & Spindle (**Fig. 1**):
Press Spindle using arbor press to remove Steel ball 7.
Spindle can now be removed from Hammer.
4. Spur gear 29 can be removed by removing Ball bearing 3009 and Pin 6.

Fig. 1

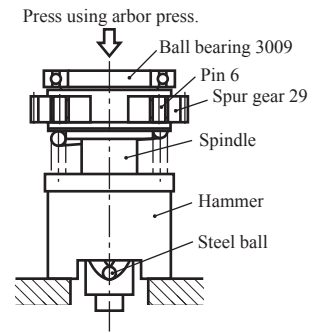

► **Assembly order and notes**

1. Apply grease to the cam contact portion of Hammer and the groove where Steel ball 4 (30 pcs) are to be set, then put Steel ball 4 (30 pcs), Flat washer 30, Compression spring 37, Flat washer 36 in place. (**Fig. 2**)
Apply grease to the cam groove of Spindle and the surface that contacts Hammer, then insert Spindle into Hammer as drawn in **Figs. 2** and **3**.
Note: Make sure the correct quantity (30 pcs) of Steel ball 4 are set in place before putting Flat washer 30 on the balls.

Fig. 2

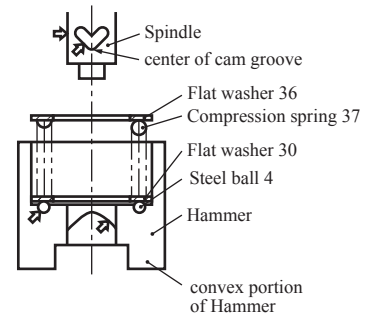

2. Put the Spindle-Hammer assembly upside-down on arbor press. Press down the convex portion of Hammer using arbor press, then insert Steel ball 7.1 from the Hammer convex portion one by one. Raise Hammer back to the initial position little by little. (**Fig. 3**)
Note: When turning the Spindle-Hammer assembly upside-down, press Compression spring 37 in order not to allow Steel ball 4 to fall out of the groove of Hammer.

Fig. 3

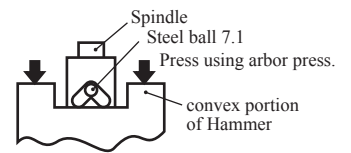

3. Apply a proper amount of grease to the teeth of Internal gear 65. insert grease.
Also apply grease on Needle bearing 1412 and Gear 29 (2 pcs) before inserting Spindle into Internal gear 65.

4. Mount Flat washer 25 on Anvil. (**Fig. 4**)

- Note:** The center hole of Flat washer 25 has a bevel on one side:
- 1) Be sure to face the beveled side towards Spindle.
 - 2) Apply grease on the face of the beveled side before mounting Flat washer 25 on Anvil.

Apply a proper amount of grease on the smaller diameter section of Anvil, and put grease in the hole that accepts Spindle, then insert Spindle in the hole. Apply grease on the inner surface of Ring 65, then insert it into Hammer case. (**Fig. 4**)

Fig. 4

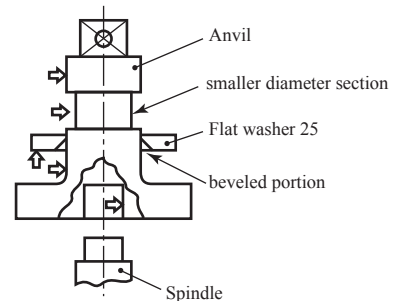

Insert the Anvil-Spindle-Hammer assembly into Hammer case. Insert Pin 5 (4 pcs) carefully into place, then fix the assembly with Retaining ring R75. Be sure to position the holes of Retaining ring R75 on the Handle side (**Fig. 5**)

Fig. 5

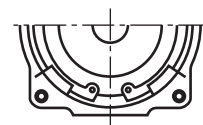

► **Circuit diagram**

Fig. D-1

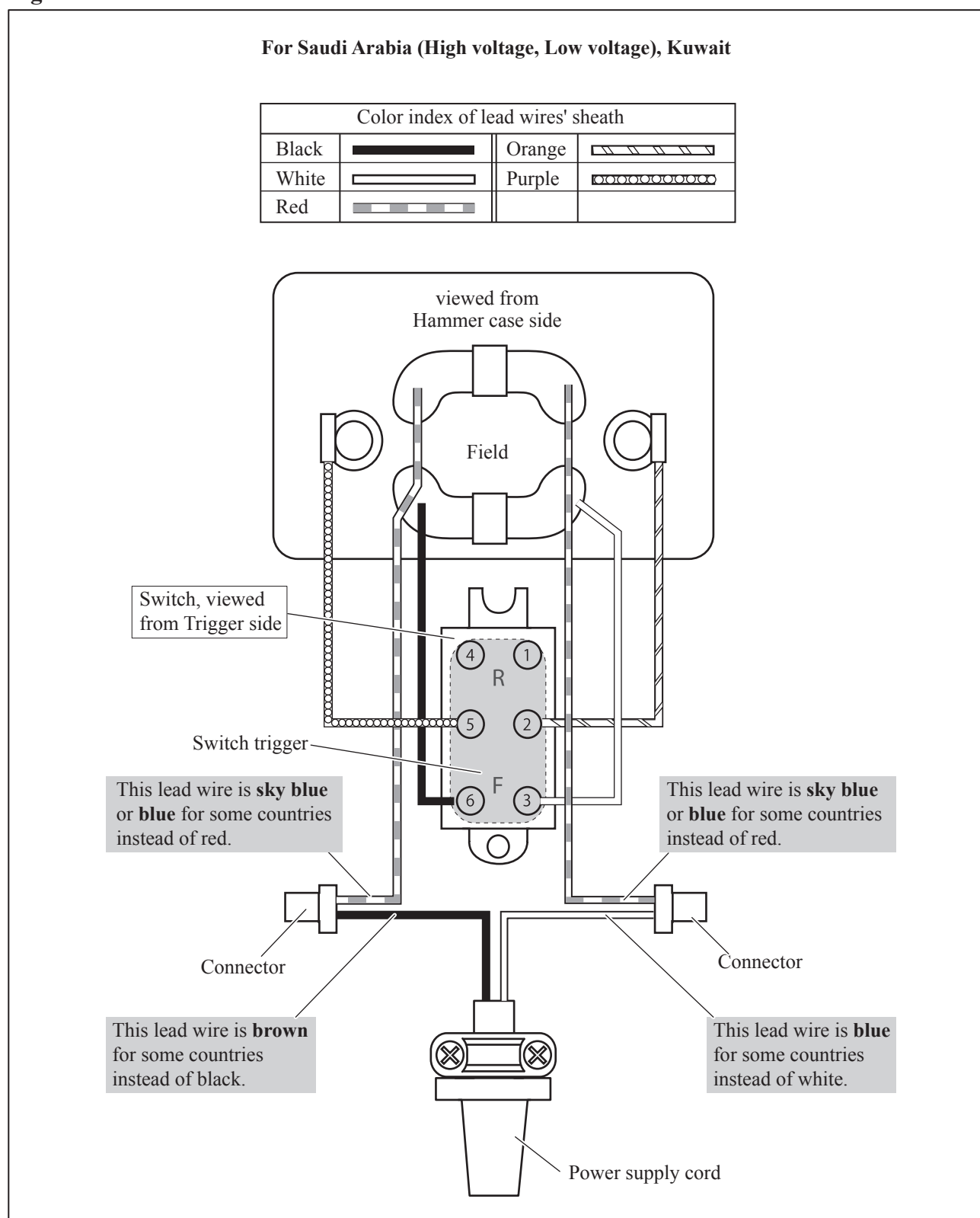

► **Wiring diagram**

Fig. D-2

