

# TECHNICAL INFORMATION

Models No. ▶ 6280D

Description ▶ Cordless Driver Drill

## CONCEPT AND MAIN APPLICATIONS

Model 6280D has been launched with the following features.

- \* Easy operation with well-balanced design
- \* Higher power than the current Model 6228D
- \* Compact design with an overall length of only 192mm (7-9/16")

This new product is available in the following variations.

Model No.	Battery	Charger	Rechargeable flashlight
6280DZ	without	without	
6280DWAE	Ni-Cd Battery 1422 (14.4V, 2.0Ah): 2 pcs	DC1414: 1 pc	without
6280DWPE	Ni-Cd Battery PA14 (14.4V, 1.3Ah): 2 pcs		
6280DWPE3	Ni-Cd Battery PA14 (14.4V, 1.3Ah): 3 pcs		
6280DWPLE	Ni-Cd Battery PA14 (14.4V, 1.3Ah): 2 pcs		ML140: 1 pc

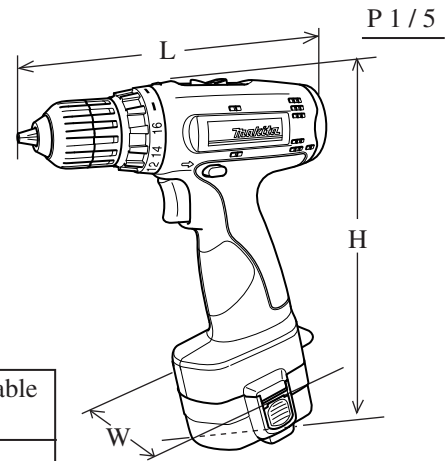

Dimensions: mm ( " )	
Length (L)	192 (7-9/16)
Width (W)	94 (3-11/16)
Height (H)	243 (9-9/16)

**Note:** All of the above models come with the items listed below in the "Standard equipment" in addition to the items listed above.

## ► Specification

Battery	Voltage: V	14.4	
	Cell	Ni-Cd	Ni-Cd
	Capacity	1.3 Ah (Battery PA14)	2.0 Ah (Battery 1422)
No load speed: (min - max rpm)		High: 0 - 1,200, Low: 0 - 350	
Chuck capacity: mm ( " )		0.8 (1/32) - 10 (3/8)	
Drilling capacity	Steel	10 (3/8)	
	Wood	25 (1)	
Max fastening torque: N.m	Hard joint	36	
	Soft joint	20	
Electric brake		Yes	
Variable switch		Yes	
Reverse switch		Yes	
Net weight: kg (lbs)		1.6 (3.5)	

## ► Standard equipment

Model No.	6280DZ	6280DWAE	6280DWPE	6280DWPE3	6280DWPLE
Philips bit 2-65	1	1	1	1	1
Battery cover	No	2	2	3	2
Plastic carrying case	No	Yes	Yes	Yes	Yes

**Note:** The standard equipment for the tool shown may differ from country to country.

## ► Optional accessories

- \*Battery 1420
- \*Battery PA14
- \*Battery 1422
- \*Battery 1434
- \*Battery 1435
- \*Battery 1435F
- \*Charger DC1414
- \*Charger DC1804
- \*Charger DC1439
- \*Automotive charger DC1422
- \*Automotive charger DC1822
- \*Assorted drill bits for wood
- \*Assorted drill bits for steel
- \*Assorted driver bits

## ► Repair

### [1] Removal/Installation of Drill Chuck

When replacing Gear assembly, remove drill chuck beforehand as described below.  
(It is not necessary to remove Drill chuck when disassembling Housing only.)

#### REMOVAL

- 1) After fully opening Chuck jaws, remove the chuck screw (M6x22 (-) Flat head screw) by turning it clockwise.  
If it is difficult to remove, use a Makita Impact wrench.
- 2) Slide Speed change lever to the position of "Low", and turn Change ring to "Drill mode".  
And then secure one end of a hex wrench with Chuck jaws. Hold the machine firmly, and then remove Drill chuck by hitting the other end of the hex wrench using plastic hammer to turn Drill chuck counterclockwise. (Fig. 1)

#### INSTALLATION

- 1) Secure one end of a hex wrench with Chuck jaws, and the other with vise.  
Shift Speed change lever to "Low", and set the machine in the mode of drilling in forward rotation. Hold the grip of the machine firmly so that your hand cannot be pulled away by reaction torque. And then fasten Spindle to Drill chuck by pulling the trigger of Switch until Spindle is locked. (Fig. 2)  
**Note:** Release the trigger of Switch just after Spindle is locked. Do not keep on pulling the trigger for longer than one second.
- 2) Fasten Drill chuck to Spindle with the chuck screw (M6x22 (-) Flat head screw) by turning it counterclockwise.

Fig. 1

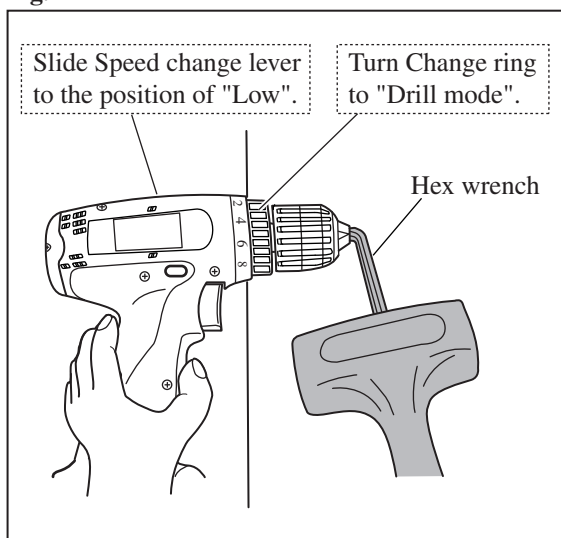
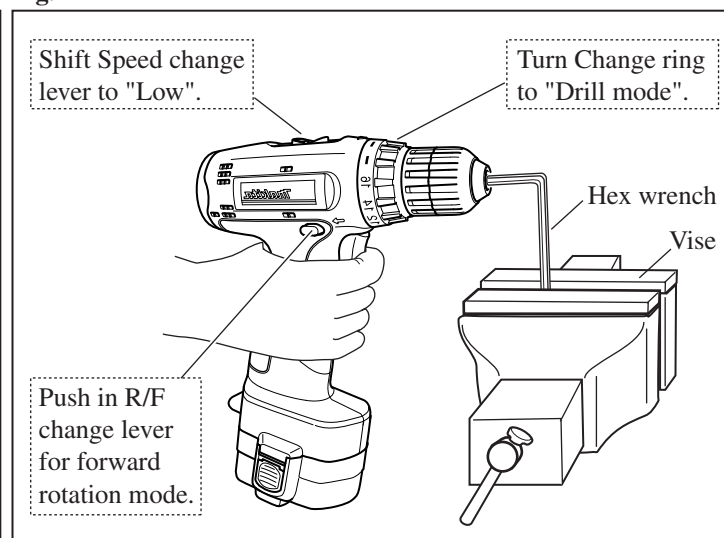

Fig. 2



### [2] Removal/Installation of Motor from/on Gear Assembly

#### REMOVAL

- 1) Pull Motor out of Gear assembly while turning it in the counterclockwise direction when viewed from the terminal end of Motor. (Fig. 3)
- 2) Remove Motor bracket from Motor by removing two Pan head screws. Now Motor can be replaced (Fig. 4)

Fig. 3

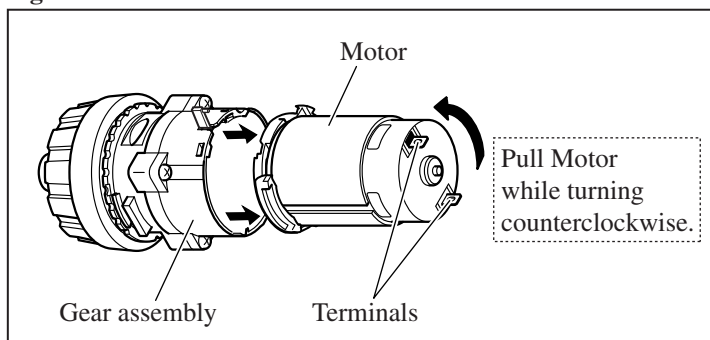
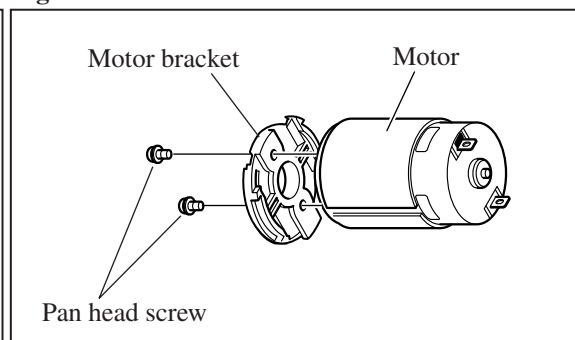

Fig. 4



## ► Repair

### [2] Removal/Installation of Motor from/on Gear Assembly

#### INSTALLATION

- 1) Place Motor bracket as illustrated in **Fig. 5**, and fasten it to Motor with two Pan head screws.
- 2) Aligning the protrusions on Motor bracket with the grooves in Gear assembly, assemble Motor to Gear assembly. (**Fig. 6**)
- 3) Assemble Motor to Gear assembly while turning it in the clockwise direction when viewed from the terminal end of Motor. (**Fig. 7**)

**Fig. 5**

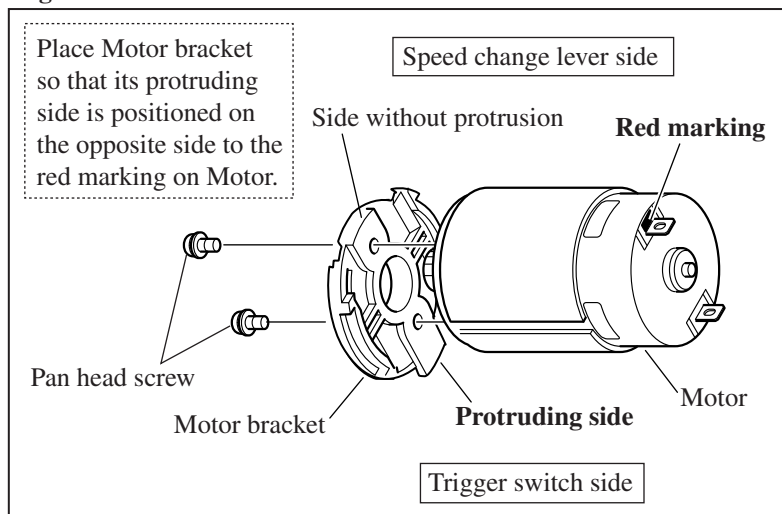

**Fig. 6**

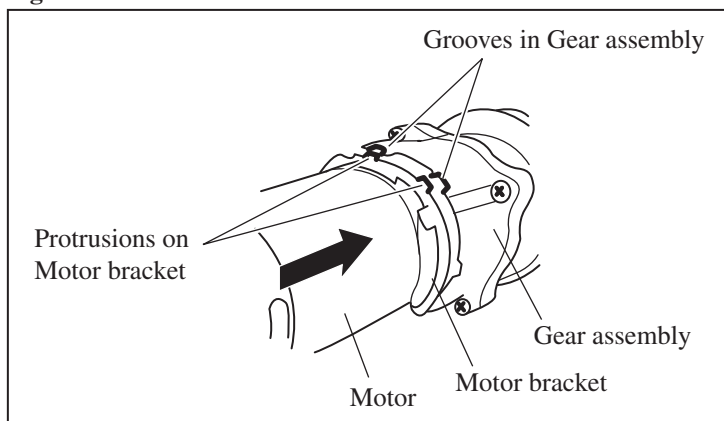

**Fig. 7**

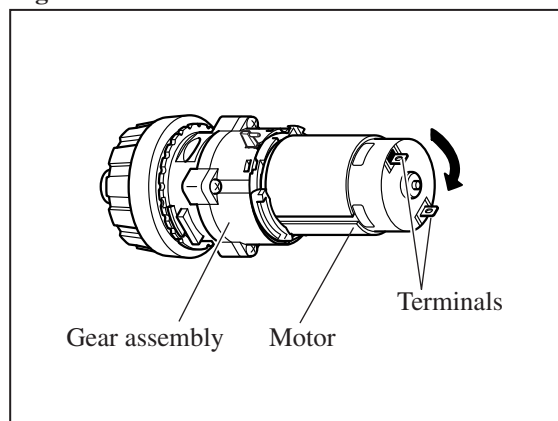

### [3] Installing Speed change Lever

- 1) Make sure that two Compression springs are set in place on Speed change lever as illustrated in **Fig. 8**.
- 2) Install Speed change lever onto the protrusion on Gear assembly as illustrated in **Fig. 9**.  
After installation, slide Speed change lever to either side. (**Fig. 10**)

**Fig. 8**

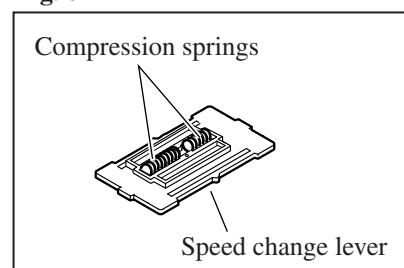

**Fig. 9**

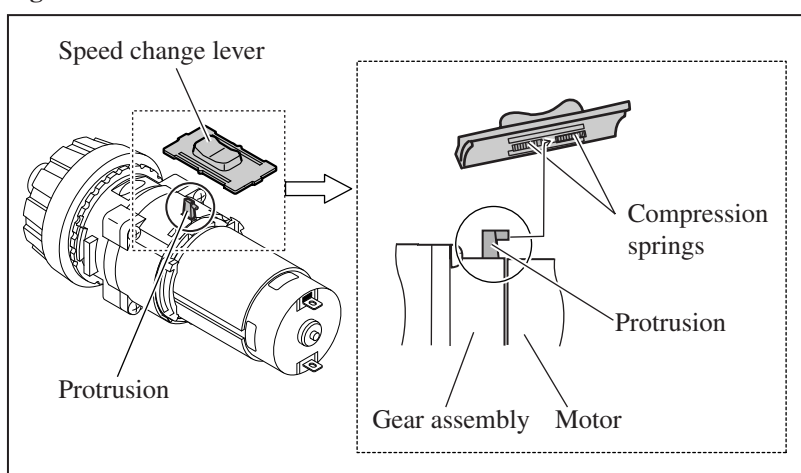

**Fig. 10**

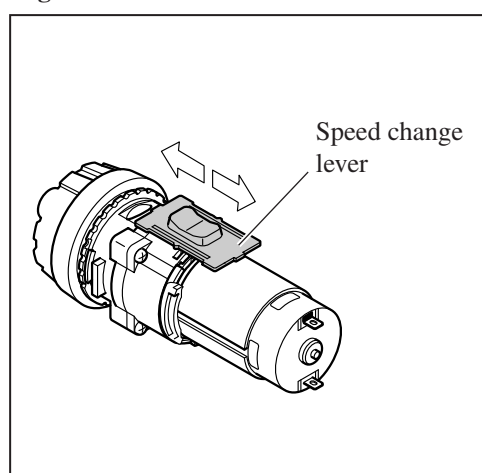

► **Repair**

**[5] Installing Leaf spring Onto Housing (L)**

Before installation of inner electrical parts, remember to set Leaf spring in place on housing (L) as illustrated in **Fig. 11**.

**Fig. 11**

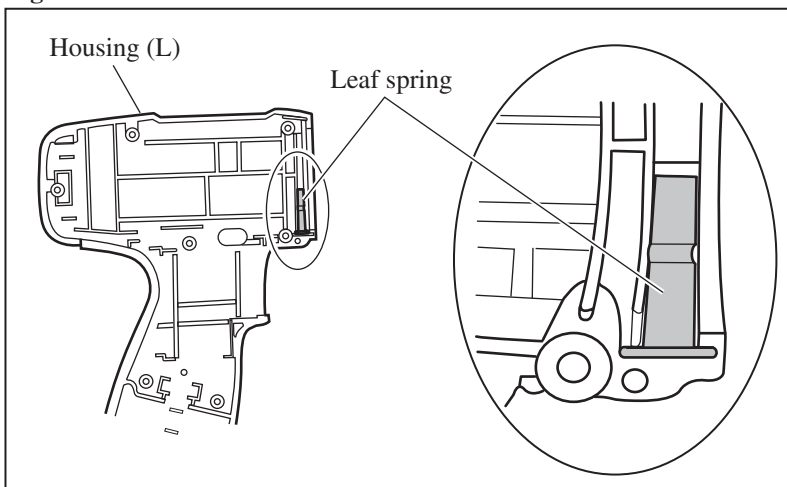

**[6] Installing Change Ring on Gear Assembly**

Install Change ring on Gear assembly as illustrated in **Fig. 12**.

**Fig. 12**

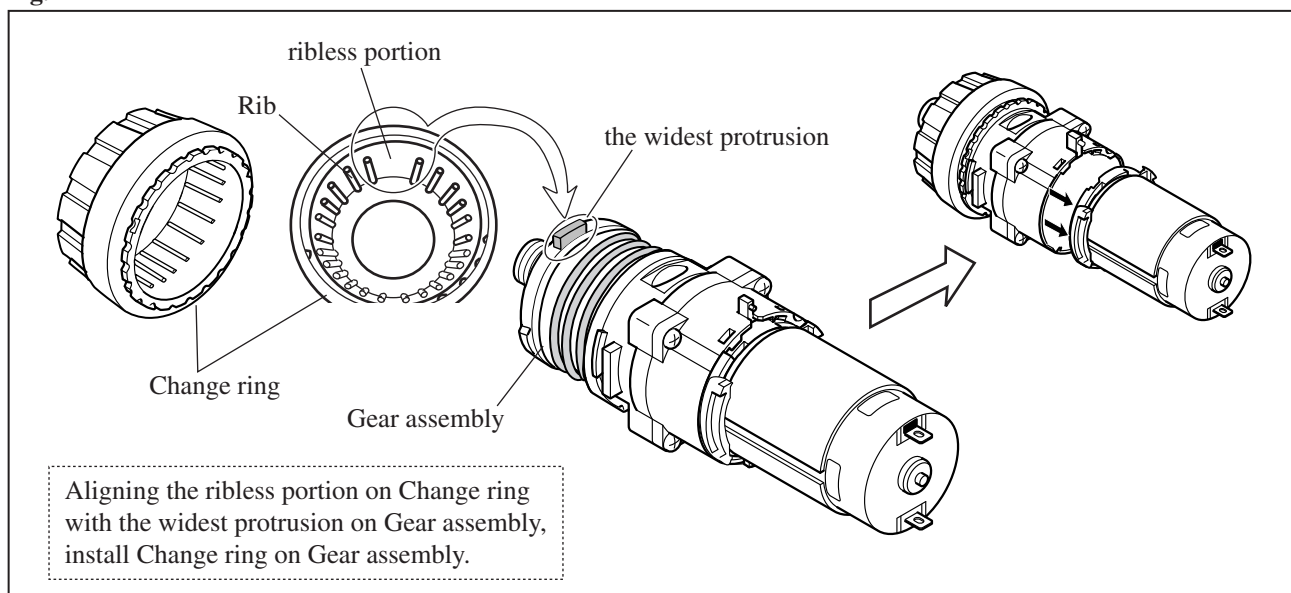



**[6] Installing F/R Change Lever**

Install F/R change lever onto Trigger switch by placing the boss on Trigger switch between the prongs on F/R change lever as illustrated in **Fig. 13**.

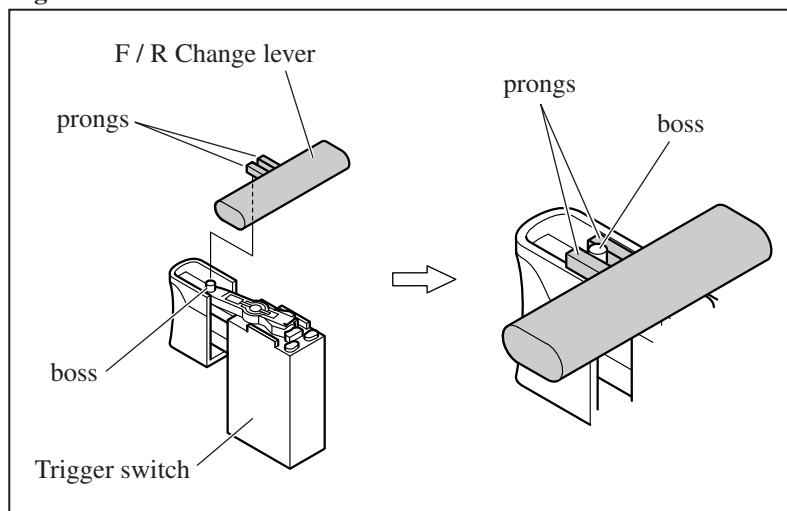
**Fig. 13**



► **Circuit diagram**

Color index of lead wires' sheath	
Black	
Red	

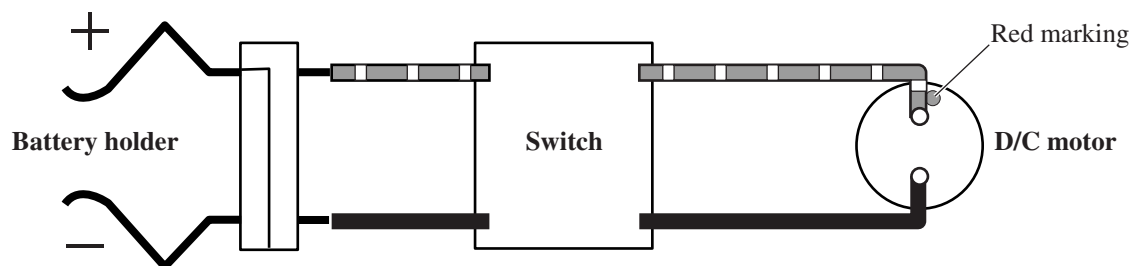

► **Wiring diagram**

**[1] Connecting Lead Wires with Motor**

Connect the lead wires with the terminals on Motor so that they are placed on the side of Housing (L). (**Fig. 13**)

**[2] Wiring in Housing**

Route lead wires as illustrated in **Fig. 14**.

**[3] Connecting Lead Wires with Battery Holder**

Connect lead wires with the terminals on Battery holder as illustrated in **Fig. 15**.

**Fig. 13**

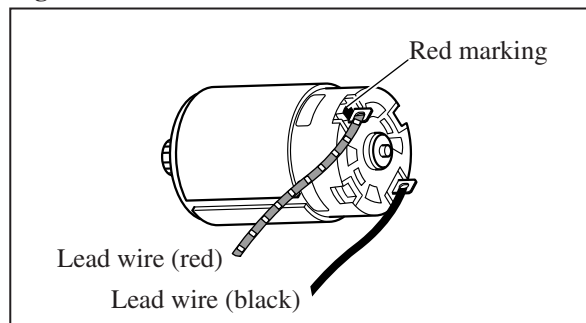

**Fig. 14**

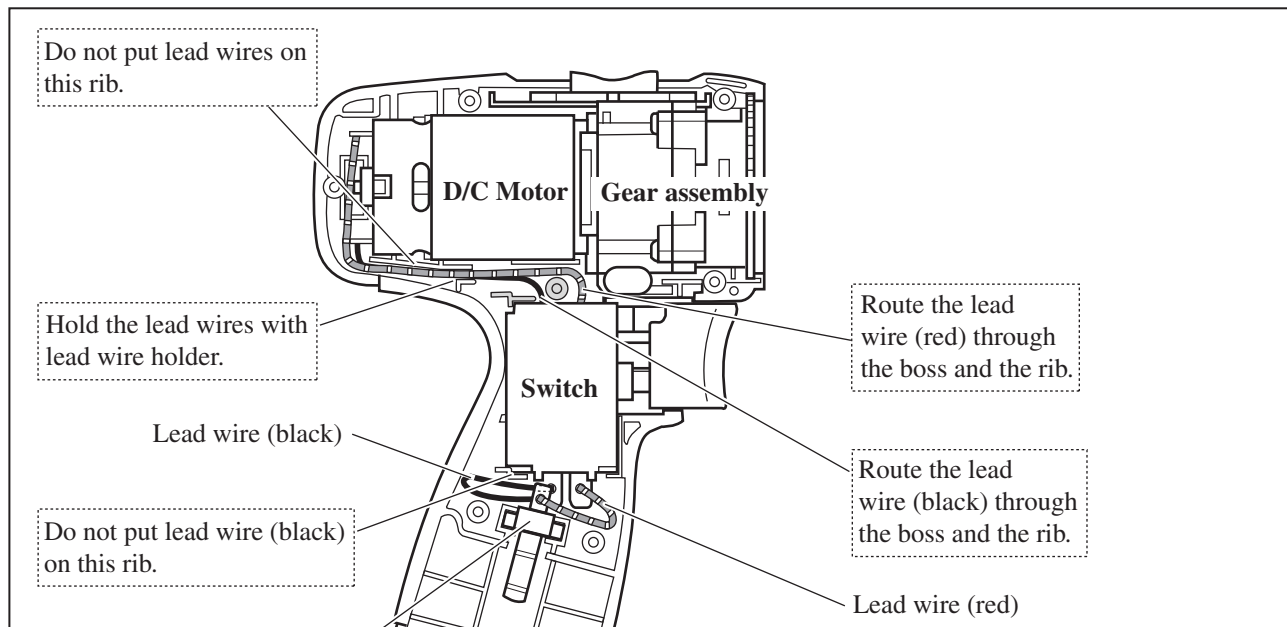

**Fig. 15**

